

UFS 8000

Controller for ultra filtration plants

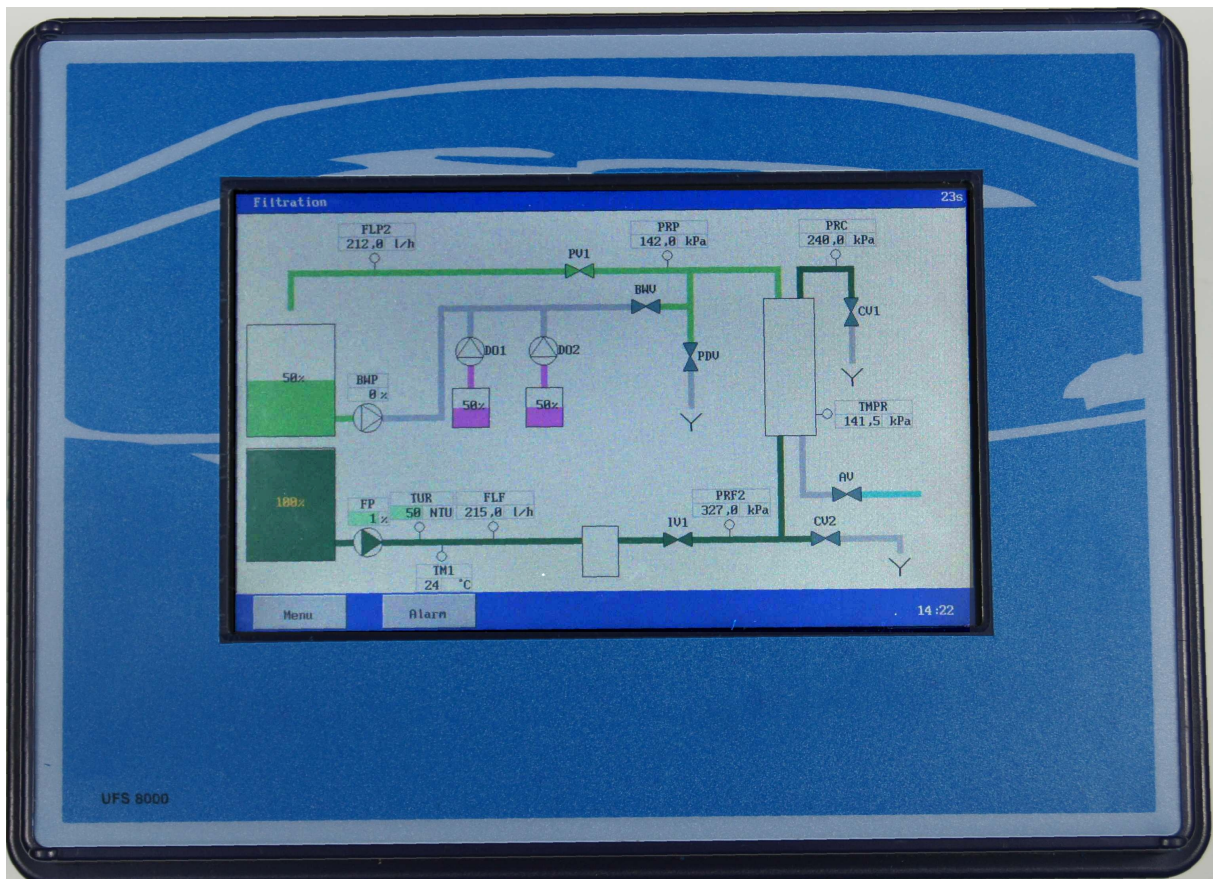

Operating manual

Software version 1.07

Contents

1. System description	1
1.1. General.....	1
1.2. Functionality overview	1
1.3. Diagram of the unit	2
1.4. Unit configuration	2
1.5. Description of the unit.....	2
2. Picture of front side.....	4
3. Measurement and function display	5
3.1. LCD display	5
4. General operation.....	8
4.1. Main screen	8
4.2. Menu.....	8
4.3. Window.....	9
4.3.1. Set value or text	9
4.3.2. On / off option.....	9
4.3.3. Set dropdown list.....	9
4.3.4. Confirmation	10
4.4. Alarm window	10
5. Unit Configuration	11
5.1. Inventory.....	12
5.1.1. Security switch	13
5.1.2. Analogue control	14
5.2. Programming	15
5.2.1. Components	15
5.2.2. Units (phases)	16
6. Components.....	17
6.1. Valves.....	17
6.1.1. Air valve.....	17
6.1.2. Inlet valves	17
6.1.3. Concentrate valves	18
6.1.4. Permeate valves.....	18
6.1.5. Backwash valve.....	18
6.1.6. Permeate dump valve	19
6.2. Pumps	19
6.2.1. Feed pump	19
6.2.2. Backwash pump	20
6.2.3. Dosing pumps	20
6.3. Alarm	22
6.4. Switches	23
6.4.1. Exceeded pressure	23
6.4.2. Stop	24
6.4.3. Filtration start.....	24
6.4.4. Start backwash.....	25
6.4.5. Alarm reset.....	25
6.5. Tanks.....	26
6.5.1. Clean water tank	26
6.5.2. Raw water tank.....	27
6.5.3. Dosing tank	28
6.6. Recorder outputs	30
6.7. Flow meter.....	31

6.7.1. Flow Feed.....	31
6.7.2. Flow Permeate 1	31
6.7.3. Flow Permeate 2	31
6.7.4. Flow Backwash	31
6.7.5. Flow meter settings	32
6.7.6. Properties flow meter	32
6.7.7. Monitoring minimum flow	33
6.7.8. Monitoring maximum flow	33
6.8. Pressure meter	34
6.8.1. Pressure Feed 1	34
6.8.2. Pressure Feed 2	34
6.8.3. Pressure Backwash	34
6.8.4. Pressure Air.....	34
6.8.5. Pressure Concentrate	34
6.8.6. Pressure Permeate	34
6.8.7. Pressure meter settings	35
6.8.8. Properties pressure meter.....	35
6.8.9. Monitoring minimum pressure.....	36
6.8.10. Monitoring maximum pressure.....	36
6.9. Turbidity meter	37
6.9.1. Turbidity meter settings.....	37
6.9.2. Properties turbidity meter	37
6.9.3. Monitoring minimum turbidity	38
6.9.4. Monitoring maximum turbidity	38
6.10. Temperature	39
6.10.1. Temperature meter settings	39
6.10.2. Properties temperature meter	39
6.10.3. Monitoring minimum temperature	40
6.10.4. Monitoring maximum temperature	40
6.11. Transmembrane pressure	41
6.11.1. Properties transmembrane pressure	41
6.11.2. Monitoring minimum transmembrane pressure	42
6.11.3. Monitoring maximum transmembrane pressure	42
6.12. pH meter.....	43
6.12.1. pH meter settings	43
6.12.2. Properties pH meter	43
6.12.3. Monitoring minimum pH	44
6.12.4. Monitoring maximum pH	44
7. UF Unit.....	45
7.1. Properties	45
7.2. Filtration.....	46
7.3. Filtration 2.....	46
7.4. Pre Flush	47
7.5. Backwash 1	47
7.6. Backwash 2	48
7.7. CEB 1	49
7.8. CEB 2	50
7.9. CEB 3	50
7.10. Integrity test.....	51
7.11. Standby	52
7.12. Standby Stop.....	53
7.13. Alarm	53
8. Alarms.....	54
8.1. General overview	54
8.2. Alarm window	54
8.3. Overview alarms.....	56
9. Manual operation of the unit	57
9.1. Standby stop	57

9.2. Integrity test	57
9.3. Standby	57
9.4. Pre Flush	58
9.5. Filtration	58
9.6. Backwash	59
9.7. CEB	59
10. Retrieve information	60
10.1. General	60
10.2. Service number	60
10.3. Inputs	60
10.4. Outputs	61
10.5. Counters	61
10.6. CEB 1	61
10.7. CEB 2	62
10.8. CEB 3	62
10.9. Alarm history	62
10.10. Ethernet	62
10.11. E-mail	63
10.12. RS485	63
10.13. RS232	63
10.14. Outputs 0-20mA	64
10.15. Inputs 0-20mA	64
10.16. Print composition in the controller	65
11. User settings	66
11.1. LCD Display	66
12. Clock	67
12.1. General	67
12.2. Time setting	67
12.3. Date setting	67
13. Language setting	68
13.1. Change language setting	68
14. Ethernet	69
14.1. Configuration	69
14.1.1. DHCP function	69
14.1.2. IP address	69
14.1.3. Subnetmask	70
14.1.4. Default gate-way	70
14.1.5. HTTP port number	70
14.1.1. Modbus	70
14.2. Access via internet (WAN)	70
14.2.1. IP address of the modem (WAN)	72
14.2.2. IP address of the modem (LAN)	72
14.2.3. NAPT	72
14.2.4. DHCP Lease	73
15. SD card	74
15.1. Arrangement of the cards	74
15.2. Directories	74
15.3. Software files	75
15.4. Log functions	75
15.4.1. Alarm log function	76
15.4.2. Data log function	76
15.4.3. Process log function	77
16. E-mail	78
16.1. Configuration	78

16.1.1. Switch on / off e-mail function	78
16.1.2. IP address of SMTP server	78
16.1.3. E-mail sender	78
16.1.4. E-mail address of the recipient.....	79
16.2. Log functions	79
16.2.1. Alarm log function	79
17. RS485.....	80
17.1. Configuration	80
17.1.1. Configuration in the controller	80
17.1.2. Configuration of the "Hyperterminal"	80
17.2. Log functions	80
17.2.1. Alarm log function	81
17.2.2. Data log function	81
17.2.3. Process log function.....	82
17.1. Modbus.....	82
18. RS232.....	82
19. Hard disk	83
19.1. Back-up via the fitting contractor.....	83
19.2. Back-up by the end user	83
20. Logging	84
20.1. Alarm data	84
20.1.1. CSV format.....	84
20.1.2. XML format.....	85
20.2. Data information	85
20.2.1. CSV format.....	86
20.2.2. XML format.....	86
20.3. Process data	87
21. Modbus	88
21.1. Registers	88
21.1.1. Register : values	88
21.1.2. Register : unities / decimals	89
21.1.3. Register : others	90
22. Internet	91
22.1. Access via the local network (LAN).....	91
22.2. Access via internet (WAN)	91
22.3. Security.....	91
22.4. Head page	92
22.5. Unit display	93
22.6. Controller display / operation.....	93
22.6.1. Protection	94
22.6.2. Terminal mode	94
22.7. Getting log files.....	94
22.8. "Internet key"	94
23. Service	95
23.1. Service number	95
23.2. Maintenance	95
23.3. Names	96
23.4. Resets	96
23.5. Hard disk	96
23.6. Hardware test	97
23.6.1. Inputs.....	97
23.6.2. Relay outputs	97
23.6.3. Outputs 0-20mA	98
23.6.4. Inputs 0-20mA.....	98

23.6.5. Back light.....	98
23.6.6. Media.....	99
24. Security	100
24.1. Controller.....	100
24.1.1. Pass word.....	100
24.1.2. Menu	101
24.1.3. Process	101
24.2. Internet	101
25. Power failure	102
25.1. Clock.....	102
25.2. Alarms	102
25.3. Programming.....	102
26. Messages	103
26.1. Hardware changed	103
27. Boot software.....	104
27.1. General.....	104
27.2. Changing application software	104
28. Frequently asked questions	105
28.1. General.....	105
28.2. Relay outputs	105
28.3. Digital inputs	105
28.4. E-mail	105
28.5. Internet	106
28.6. RS485.....	106
28.7. RS232.....	106
29. Terminology	107
30. Overview menu	108
31. Opening casing.....	109
32. Terminal block connection	110
32.1. Schematics	110
32.2. Remarks	112
33. Electrical connection examples	112
34. Installation and Start up.....	114
34.1. General.....	114
34.2. Installation	115
34.3. Ethernet connector	115
35. Maintenance	116
36. Spare parts.....	116
36.1. Order codes.....	116
36.2. Pictures.....	116
37. Technical specifications	117
37.1. Casing dimensions	118
38. Index	119
39. Declaration of conformity	121

40. Warranty conditions..... 122



1. System description

1.1. General

The UFS8000 is applicable for the automatic control and monitoring of ultra filtration units. Thanks to the flexible programmable software this controller is suitable for a large number of various water treatment applications.

1.2. Functionality overview

- Menu-driven operating and programming of controller graphic colour TFT display (800x480).
- Operates via touch panel.
- Choice of languages.
- Universally applicable to ultra filtration plants.
- Flexibly programmable for specific user requirements.
- Water production via manual controls or level switches
- Free programmable service telephone number.
- Programming locally and via web browser
- Schematic diagram via web browser
- Modbus compatible protocol through RS485 and Ethernet.
- Measurement data logging via RS232, RS485 and SD card.
- Alarm logging via RS232, RS485, SD card and E-mail.
- 8 free programmable inputs for potential free switches.
Available input functions: High-level switch, Low-level switch, Overpressure, Start Backwash, Start Filtration, Alarm reset, Security switches for valves / pumps and Level switch for dosing tank
- 7 free programmable relay outputs
Available relay functions: Feed pump, Air valve, Inlet valve, Concentrate valve, Permeate valve, Permeatedump valve, Dosing pump, Backwash valve, Backwash pump and Alarm.
- Optional: 2 x print with 3 outputs 0(4)-20mA for writer or control frequency regulator.
- Optional: 4 prints with 3 programmable inputs 0-20mA.
Available measuring functions: Level of the clean water tank, Level of the raw water tank, level of dosage tank, flow measurements, pressure measurements, temperature and pH meter.
measurement and turbidity measurements.
- Alarm history: last 20 alarms are stored with date and time
- Update of software via SD card
- Date and time with battery
- Securing program information in the event of a loss of voltage, the program information is stored without battery.
- Manufactured according to EMC guidelines.
- Casing suitable for wall mount, mounting and *panel* mounting.
- Available in 24V, 115V, 230V, 240V, 115/24V, 230/24V, 240/24V

1.3. Diagram of the unit

The unit is schematically represented in the following diagram

The diagram features all the components defined in the controller. Only the components that are connected to the available in- and outputs can be displayed.

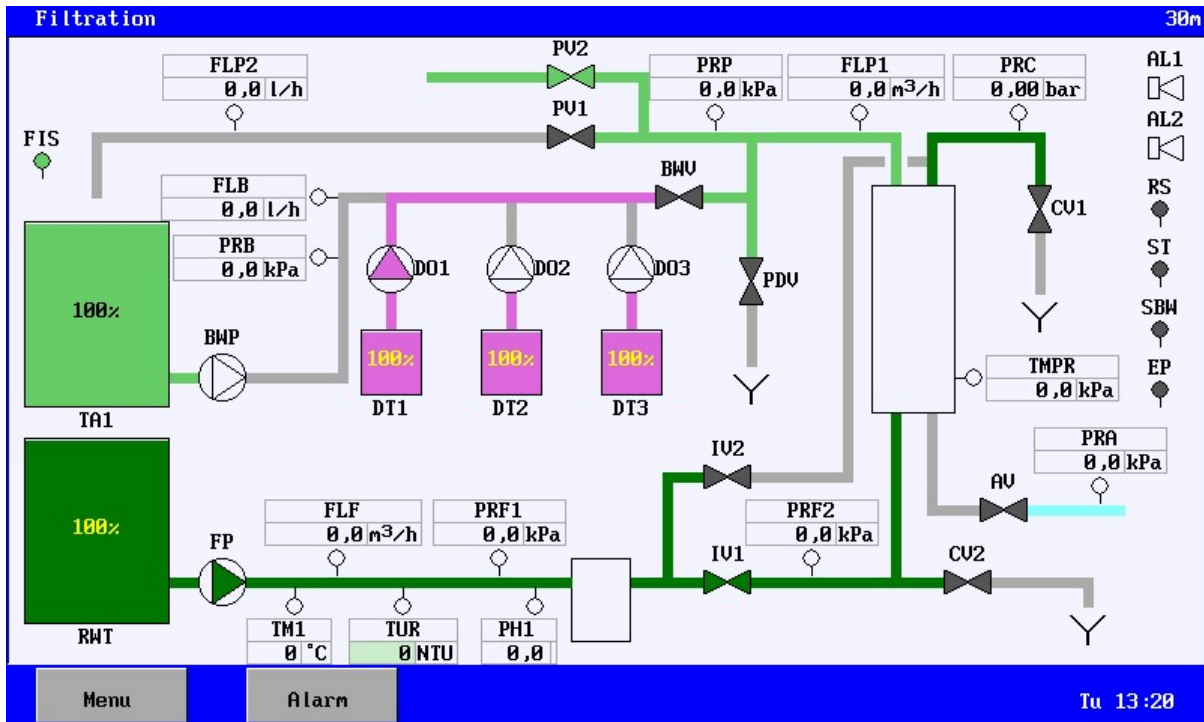

§ 29 “Terminology” on page 107 offers an overview of the meaning of the abbreviations used.. These abbreviations may differ from the picture, because they have been modified by the user.

1.4. Unit configuration

In the controller the unit configuration can be configured via the menu option “Unit” (in the main menu). First of all, an inventory has to be made of the components that have to be driven by the controller, and to which pins these components are connected. The inventory is described in § 5.1 “Inventory” on page 12.

Subsequent to the inventory any delays, limits etc. can be set for the various components under the “Programming - Components” option. This is described in § 6 “Component” on page 17.

Next the various phases (“Filtration”, “Pre Flush” etc.) can be programmed.

The functions that are switched on or switched off can be set for each phase. A time duration may also be entered. This is described in § 7 “UF Unit” on page 45.

1.5. Description of the unit

The controller distinguishes different phases:

- | | |
|------------------|---|
| - Filtration | Production of water |
| - Pre Flush | Flushing the membrane before filtration |
| - Backwash 1 | Rinsing the membrane (e.g. from bottom) |
| - Backwash 2 | Rinsing the membrane (e.g. from top) |
| - Integrity test | Checking the membrane |
| - CEB 1,2 and 3 | Rinsing the membrane with chemicals |
| - Standby | Installation out of service : no production of water |
| - Standby Stop | Installation out of service : only be switched on manually. |
| - Alarm | Installation out of service : no production of water |

The controller is routinely delivered in the "Standby Stop" phase. The unit will not be automatically started until this is switched on manually (see § 9.1 "Standby stop" on page 57). Once it is switched on, the controller will no longer start in this phase after a power failure, unless this phase is activated via the programming (see § 7.12 "Standby Stop" on page 53).

The production of water can be started depending on the level in the tanks, the "start filtration" switch (if enabled) or manually.

It is possible to disable the installation manually during the "Filtration" phase (see § 9.5 "Filtration" on page 58), regardless of the level in the tanks or the position of an eventual "start filtration" switch. The installation will go on "Standby" after this phase (depending on the programming, eventually by a backwash).

The lower bar in the main window will then show that unit has been manually switched off. The unit will no longer be automatically switched on until the unit is manually turned on again.

It is further possible to activate a backwash or chemical rinse during the production (see § 7.7 "CEB 1" on page 49, § 7.8 "CEB" on page 50 and § 7.9 "CEB" on page 50).

One backwash phase is activated as a standard. A second backwash phase, however, can be activated (see § 7.6 "Backwash 2" on page 48). With this a distinction can be made between a backwash via the top and bottom of the filter.

If an eventual chemical rinse is dependent on the number of executed backwashes, then, in the case of two activated "normal" backwashes, "Backwash 2" is checked for the counter of the number of executed backwashes. If "Backwash 2" is not activated, then "Backwash 1" is, of course, checked.



Also a second filtration phase ("Filtration 2") can be activated (see § 7.3 "Filtration 2" on page 46) to perform "top / bottom" filtration.



A chemical rinse will follow immediately after the respective backwash. If there are any chemical rinses occurring simultaneously, then these will be carried out directly after one another.



For "Chemical rinse 2" (CEB 2), the interval can also be made dependent on the "Chemical rinse 1" (CEB 1) phase. In this case, the cycle will be as follows:



Also see § 7.8 "CEB" on page 50.

For the testing of a "leak" in the membrane, the "Integrity Test" phase is present in the control unit. This phase can only be achieved through the "Standby" phase (see § 9.3 "Standby" on page 57). The test is not started automatically immediately, but the system is initially in a "rest" position. The actual test can be started from this position (see § 9.2 "Integrity test" on page 57). There is more information on the "Integrity Test" phase in § 7.10 "Integrity test" on page 51.

If a phase is interrupted because of an alarm situation the top bar will show there is an alarm situation. Also shown is the phase when the alarm occurred, the cause of the interruption and how the unit is switched on again.

§ 7.13 "Alarm" on page 53 In § 8 "Alarms" on page 54 there is more information about alarms.

2. Picture of front side

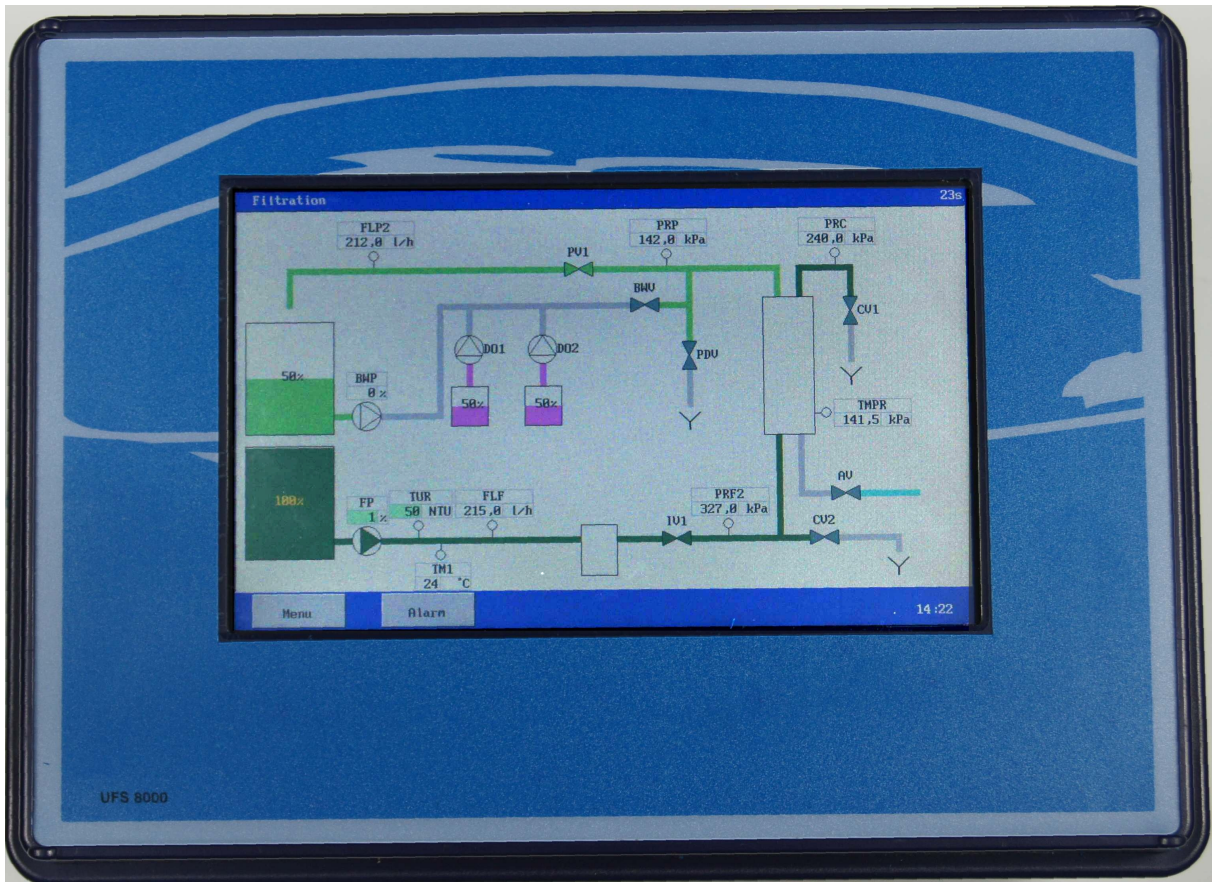

1 LCD display + touch panel

3. Measurement and function display

3.1. LCD display

The LCD display features further information about the active process.

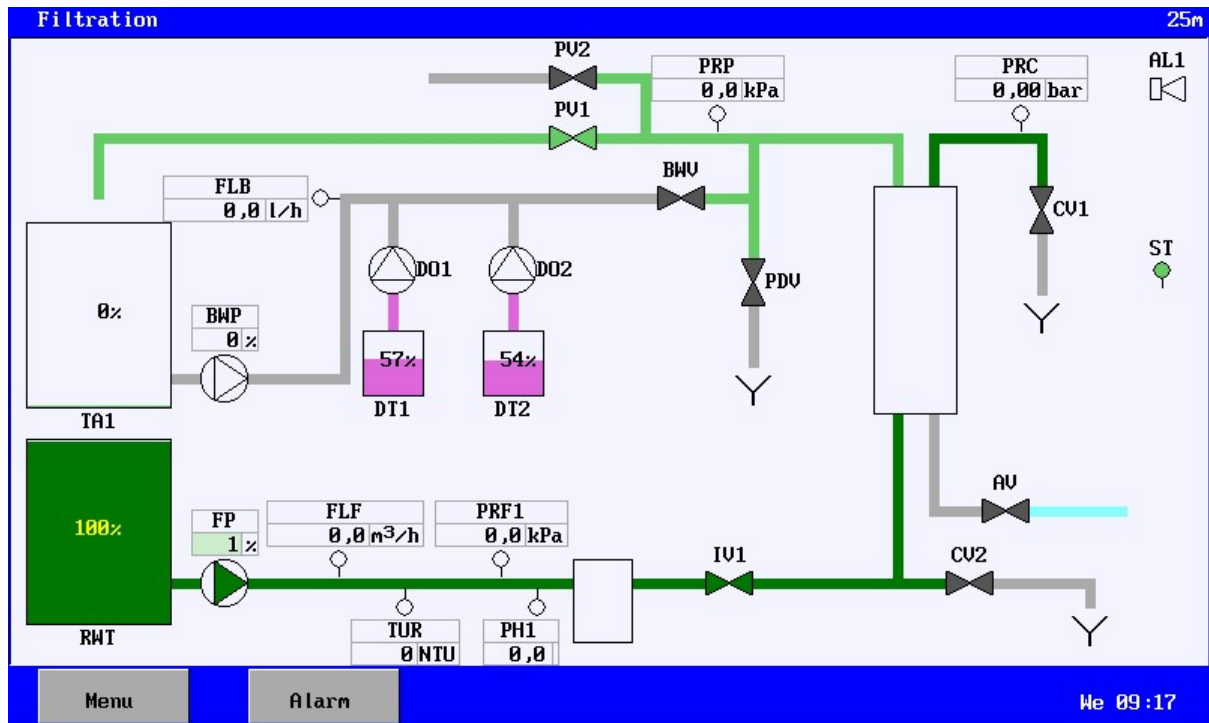

The top bar displays the process the unit is in. Also shown are the measurement values or statuses of the connected components.

Piping

The pipes can have various colours.

These colours have the following meanings:

- no medium
- unrefined water
- permeate
- chemicals
- air

Measured Values

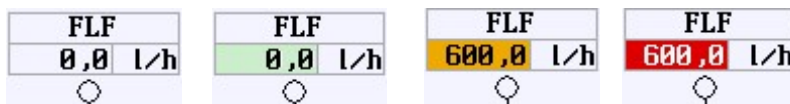

The measured values can be displayed with various background colours.





These colours have the following meanings:

- white : the measured value is not monitored.
- green : the measured value is monitored and is in order.
- orange : the measured value is too high or too low, but the delay time is not over yet.
- red : the measured value is too high or too low and the delay time is over.



Positions of the inputs:

The (digital) inputs can have the following statuses:

- 
 The input function is not supervised (grey).
- 
 The input function is supervised and inactive (green).
- 
 The input function is supervised and active, but the time delay is not finished yet (yellow).
- 
 The input function is supervised, active and the time delay is finished (red).

Positions of the outputs:

The symbols can be displayed in the following colours.

Pumps:



- white : The pump is turned off.
- dark green : The pump is turned on and unrefined water is being pumped.
- light green : The pump is turned on and permeated water is being pumped.
- purple : The pump is turned on and chemicals are being pumped.
- red : The pump is turned off. There is a malfunction in the pump.

If the pump is controlled via a frequency regulator and the reference for the frequency regulator is set via the controls, then the set percentage is displayed.

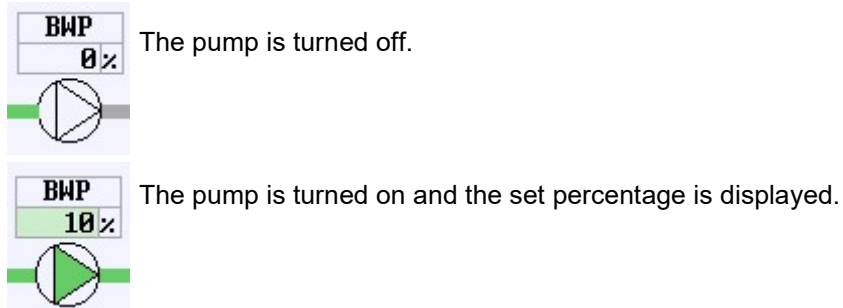

Shut-off Valves:



- dark gray : The valve is closed.
- dark green : The valve is opened and unrefined water runs through.
- light green : The valve is opened and permeated water runs through.
- light blue : The valve is opened and air is let through.
- orange : The security of the valve is activated, but the delay time has not yet passed.
- red : The security of the valve is activated and the delay time is over.

Attention: If the pulse function for the dosing pump output is activated a “|” will also be displayed next to the deactivated relay.



Situation of the tank

The tanks can be displayed with different background colours. These colours have the following meanings:

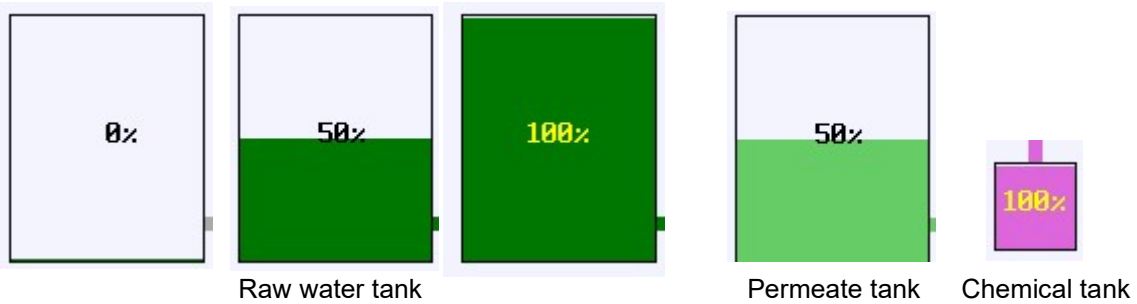

If the tank is equipped with level measuring (0(4)-20mA), the level will be indicated per ratio.

Status bar:



There are keys on the status indicators that allow you to activate the menu or the alert window. The lower bar is used to display an exceptional situation (such as a manual stop) and the current time. The warning corresponds to the phase running at that time. The corresponding phase in § 7 “UF Unit” on page 45 offers further information about any warning there may be.

Menu

In the menu, the windows have been provided with a unique number in the top right-hand corner.

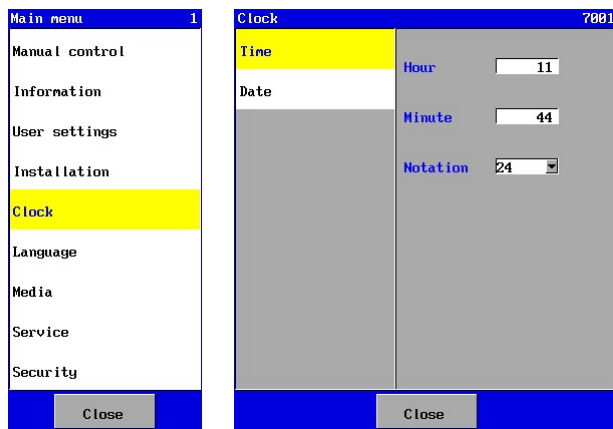

This can be used to check whether the correct window is selected at all times (in the case of telephone support, for example).

4. General operation

A touch panel is used for the operation and programming of this controller. Details are provided below about the general arrangement of the screen, the meaning of the various "keys" and the general display /input windows.

4.1. Main screen

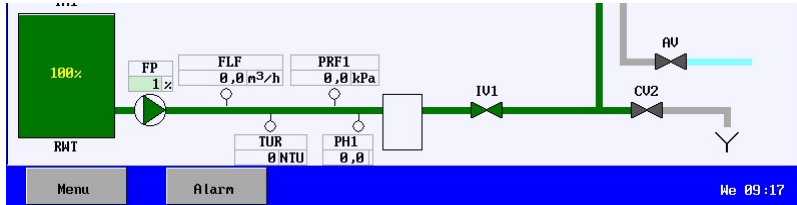

In the main screen the keys have the following functions:

Menu To the menu. **Alarm** To the alarm window

4.2. Menu

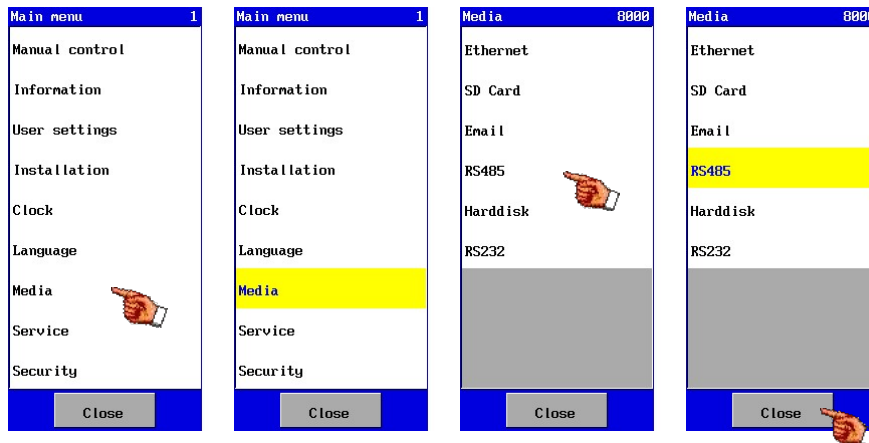

You can select the different items within the menus. The selected item will be displayed in yellow and the subordinate menu or windows will be displayed.

If the selected menu consists in several submenus, the two last menus will be displayed. The menu can be closed by pressing the **Close** button.

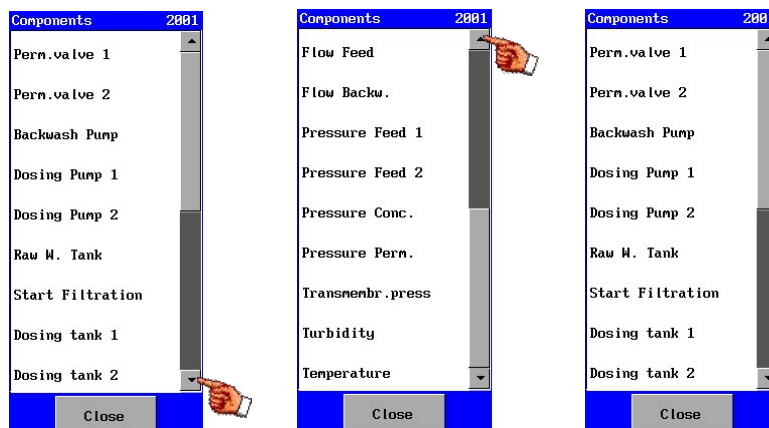

If the number of menus is bigger than the number of available positions, the menu will appear in a scroll bar. The previous or next (invisible) items are reachable through the up and down arrows.



4.3. Window

The various settings can be made in windows.
 The different types of settings are: values, texts and dropdown lists.

4.3.1. Set value or text

The box with the required settings has to be selected to change a value or text and calling up a new window where the value / text can be changed.

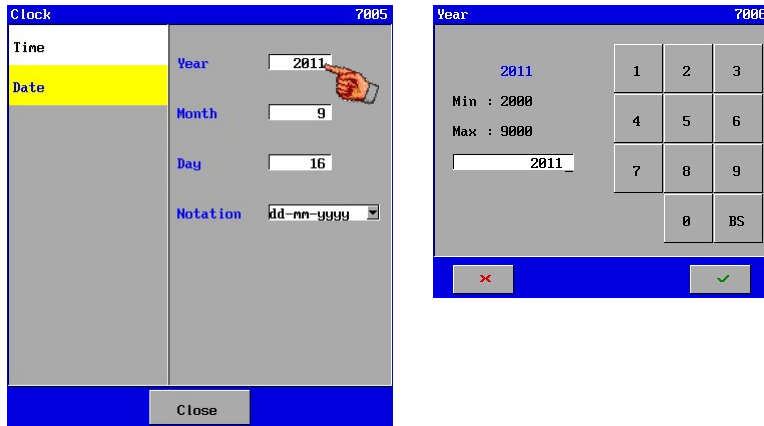

This window invariably has three choices with a special meaning:

- Confirm the (changed) setting. You then quit the window.
- If you exit a window, the modified values will not be saved.
- (Backspace) Erase last character.

The changed setting is stored in the memory after you quit the main menu.

4.3.2. On / off option

The menu features the so-called “on/off” options.

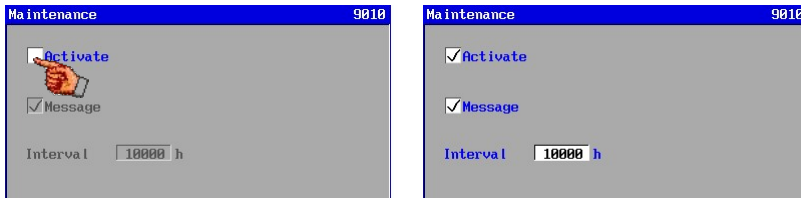

If the “check” mark appears the option is switched on. Other settings can be activated and appear by switching on this option.

4.3.3. Set dropdown list

A dropdown list is identified by a field with an arrow pointing downwards on the right-hand side.

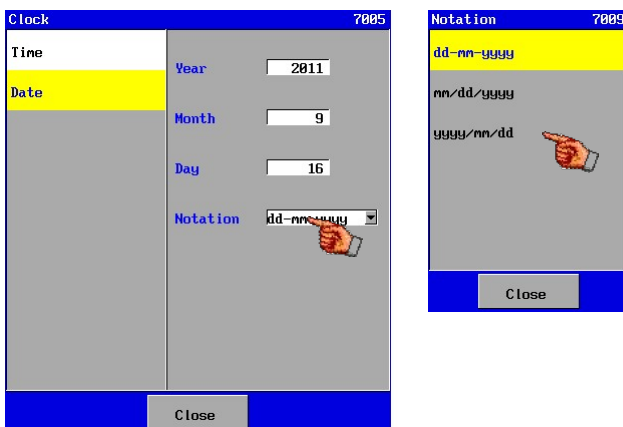



Pressing the dropdown item thus calling up a window with a list of options.





Confirming the choice calls up another window for the final confirmation.



 Confirm the choice again.
 Cancel the choice.

The changed setting is stored in the memory after you quit the main menu.

4.3.4. Confirmation

In some cases confirmation is required subsequent to a choice or change. The  key can be used to confirm the choice or change. The  key can be used to cancel the choice or change.

Example:



4.4. Alarm window

The operation in the alarm window is described in § 8.2 “Alarm window” on page 54.



5. Unit Configuration

This chapter describes how the unit may be configured.

The unit configuration option is featured in the main menu.

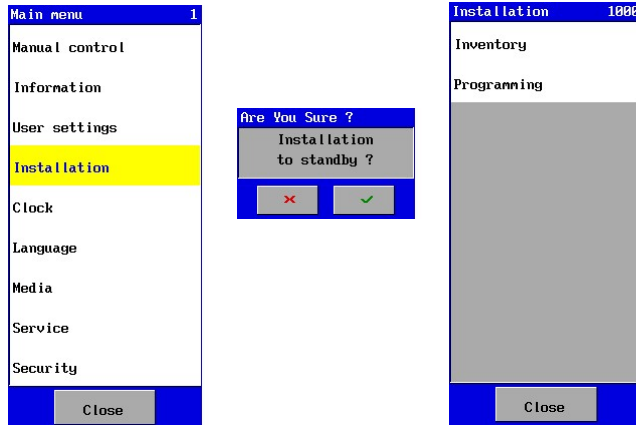

If the unit configuration is selected you will be asked if the unit may be placed in Standby. The configuration may be accessed only if the unit is in Standby.

If the unit is placed in Standby the following window will appear where a choice is made between the inventory of the connected components and the programming of the components and the phases of the UF unit.

The inventory first of all has to be made after which the inventoried components are programmed and activated during the UF unit's various process phases.

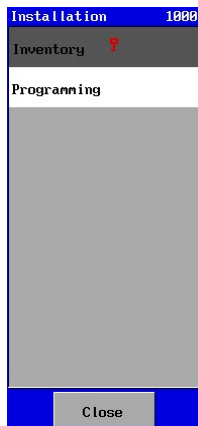

The inventory menu may be secured against unauthorised changes, upon which a key appears after "Inventory" to show the option is secured (see also § 24.1.2 "Menu" on page 101).

5.1. Inventory

Before the components and process phases can be programmed, an inventory has to be made of the components with the corresponding properties.

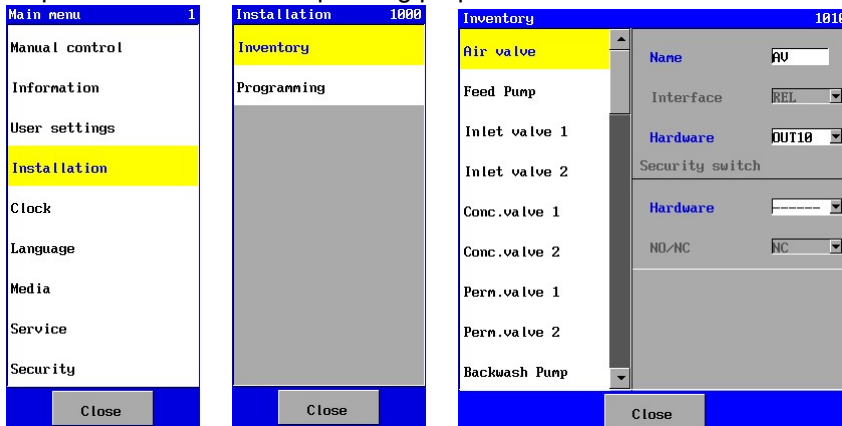

Selecting the item "Inventory" calls up a list of potential components that may be connected. If a specific component from the list is connected to the controller the component's corresponding window can indicate which pins the component is connected to.

The specific properties of a component may also be entered, such as a cell constant or whether a switch is "normally open" or "normally closed".

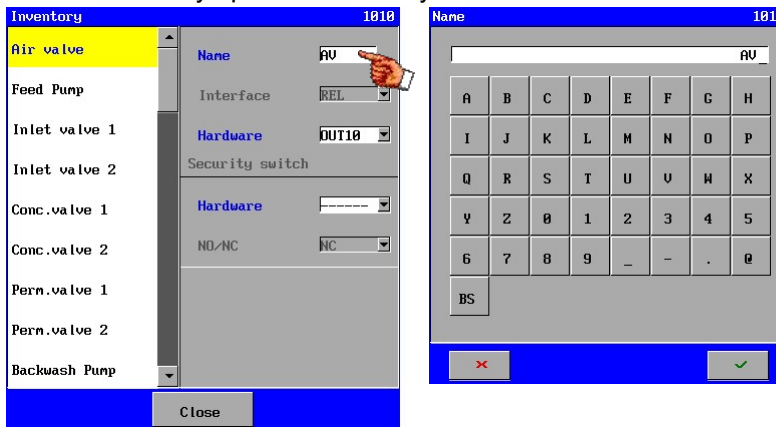

An own name or code can be set for each component (maximum 6 characters). This name will be displayed in the diagram and in the log data.

When a component is connected to the controller "Hardware" can show which pins the component is connected to.

An overview is provided of the hardware to which the corresponding component can be connected. It also indicates which hardware is already occupied.

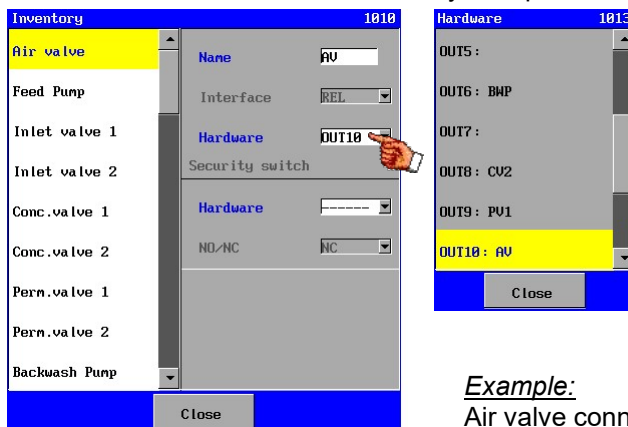

Example:
Air valve connected to OUT10.

If a component is not connected, then the “----” option should be chosen. This disconnects hardware and software.

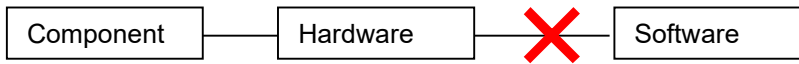

The component will then no longer be listed in the remaining settings, unless the component was connected to another component in the settings for that other component. In that case, the text will be “crossed out”.

When a component has to be moved to other terminals, where a component is still connected, an automated process has to be used to release the component that is detached. The component can then be connected to the terminals made available.

5.1.1. Security switch

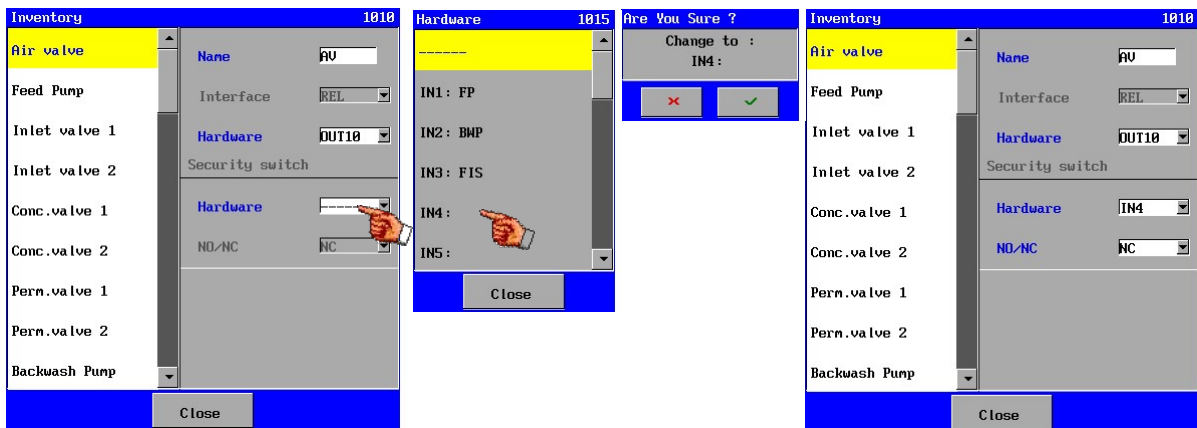

Circuit breakers can be activated in certain components, such as valves and pumps. These can be linked to one of the available inputs and it can be indicated whether the switch is “normally closed” or “normally opened”.

The delay on an alarm indication for the valves is fixed at 4 seconds. For the pumps it is 1 second by default.

If a circuit breaker has been defined, it will always be monitored.

If an alarm situation occurs, then the name of the respective valve will be displayed as a notification.



5.1.2. Analogue control

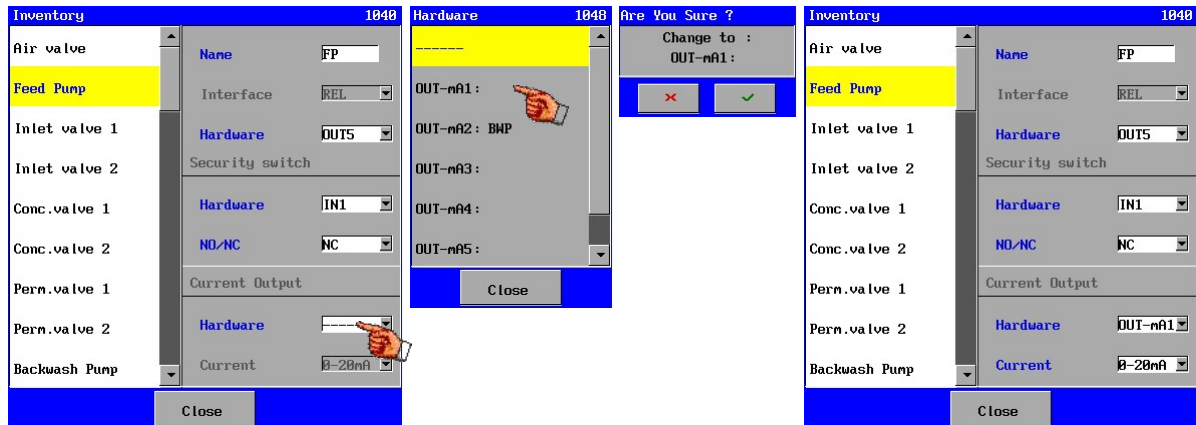

Certain components can be controlled via an analogue output (such as a pump via a frequency regulator). An analogue output can be selected for these components. In the settings of the processes (see § 5.2.2 “Units (phases)” on page 16) it can subsequently be set to any percentage of the current range (0-20mA or 4-20mA); the output current must be set.

This output in a frequency converter can, for instance, be used as a “target value”. The flow or pressure that must be regulated can, via the “recorder function”, also be directed to the frequency regulator.

If an analogue output has been activated for the relevant component, then a percentage of the range of the analogue output can be set.

If a percentage of 0% is entered, then the relevant relay output can be switched off; at a different value, the relay output is activated.

If an inventory window for a specific component differs from the windows shown here more information about this can be found in the corresponding component in § 6 “Component” on page 17.



5.2. Programming

Subsequent to the inventory of the components and entering the specific properties of the components, you may enter other properties in the component programming and the various phases of the UF unit can be set.

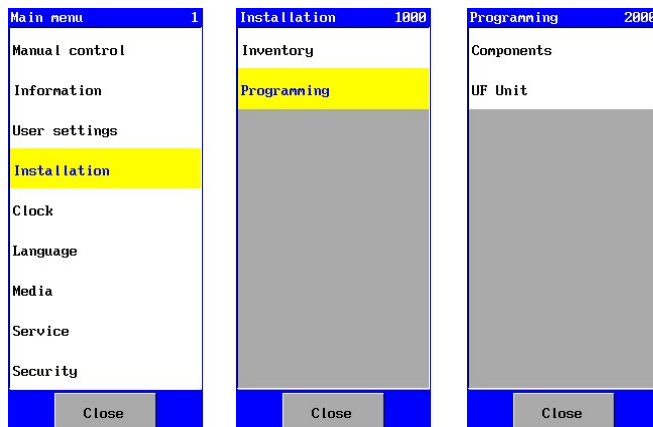

The program menu can be secured against unauthorised changes. A key then appears after “Programming” to show the option is secured (see also § 24.1.2 “Menu” on page 101).



5.2.1. Components

The features of a component can be programmed.

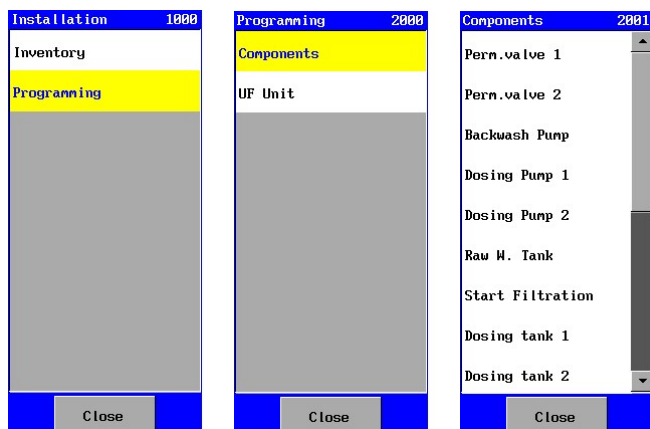

If other settings are required for the component the component is not displayed in the programming list for the components. Nor will a component be displayed in the list if this is not connected (not linked to the hardware)

More information about the programming of a component can be found in § 6 “Component” on page 17.



5.2.2. Units (phases)

Once the components have been inventoried and programmed the various process phases of the RO unit may be programmed.

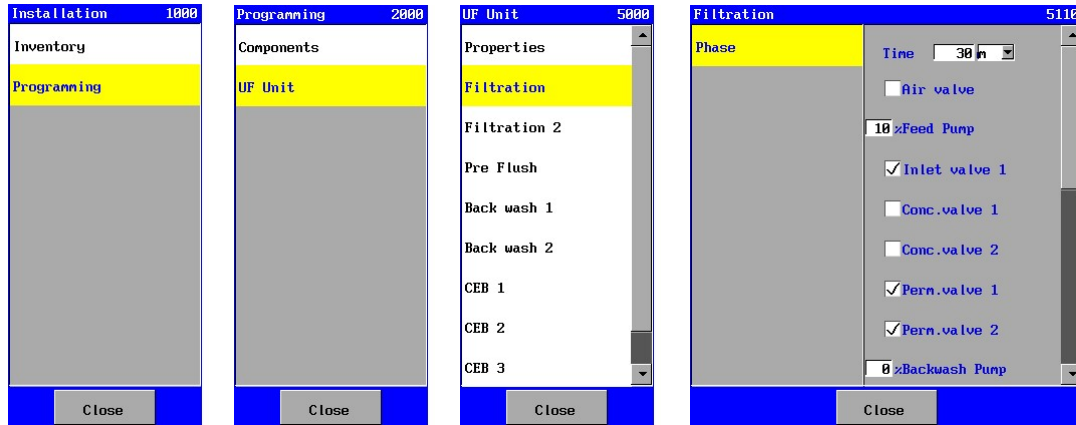

Only the programmable phases will be displayed.

During a “time” phase the time is entered (0-999) in seconds or minutes. If a time of 0 is entered the corresponding phase is omitted.

It may also be shown in each phase which components are activated.

If an analogue output has been activated for the relevant component, then a percentage of the range of the analogue output can be set.

If a percentage of 0% is entered, then the relevant relay output can be switched off; at a different value, the relay output is activated.

In the settings of the phase “Backwash 1”, “Backwash 2”, “CEB 1”, “CEB 2” and “CEB 3”, the name of the sub-process can be set. This is because the order of the sub-processes for this phase is not always identical for every installation.

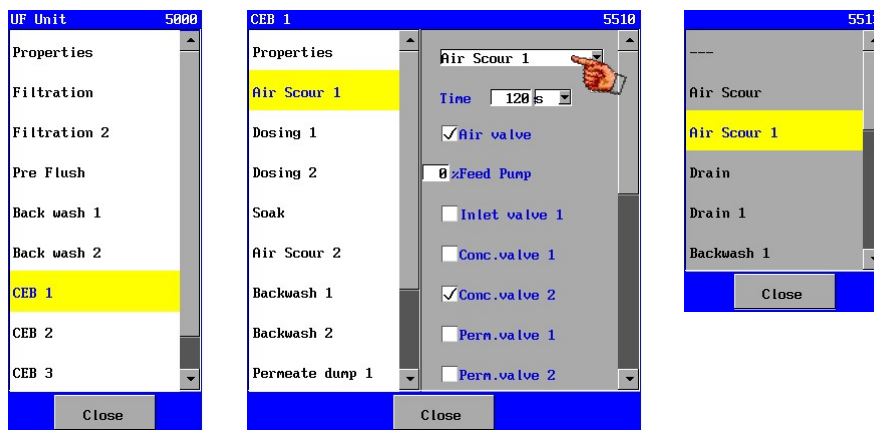

If a component is not displayed this means it is not connected or the component cannot be set for this phase.

More information about the programming of the process phases is featured in § 7 “UF Unit” on page 45.

6. Components

An examination is made in this chapter of the inventory and programming options for the various components that have to be connected.

This component may divided into:

- Valves
- Pumps
- Alarm
- Switches
- Storage tank
- Other

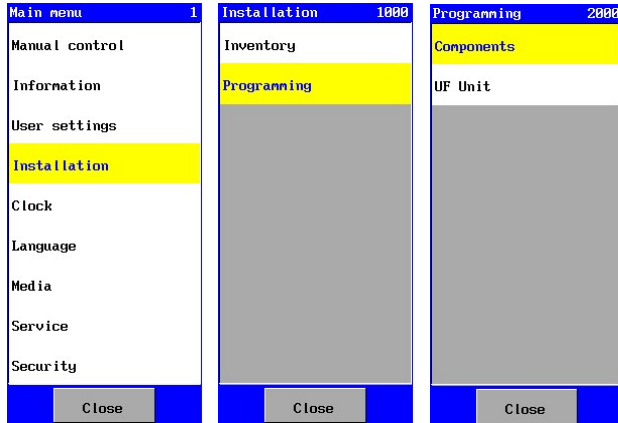

Where a reference is made in this chapter to inventory, this means the window located via the "Installation – Inventory" options. See § 5.1 "Inventory" on page 12 for more information.

Where a reference is made in this chapter to the programming of a component this means the window located via the "Installation – Programming – Components" options.

6.1. Valves

The valves may be connected only to the relay output functions (OUTx). Furthermore, a safety switch can be activated for the respective valve (see § 5.1 "Inventory" on page 12).

Whether a valve is open or closed can also be determined for each process stage.

The "Permeate valves" are alone in having other settings on top of the inventory settings.

6.1.1. Air valve

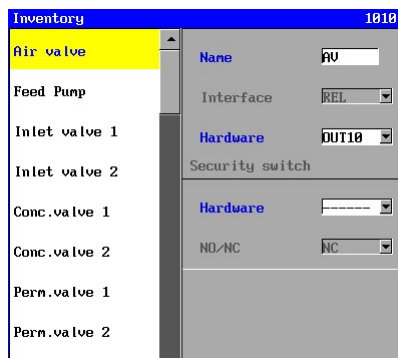

In the case of the "Air valve" all that has to be entered, in the inventory, is the relay output it is connected to.

A security switch can be activated. This can be linked to one if the available inputs, and it can be set if the switch is "normally closed" or "normally opened".

For more information, see § 5.1 "Inventory" on page 12.

6.1.2. Inlet valves

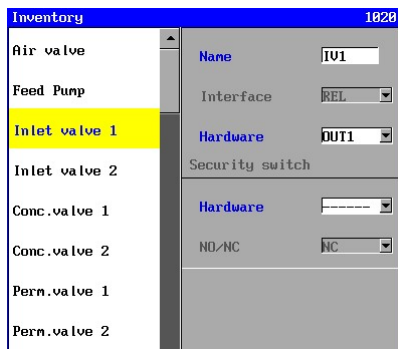

In the case of the "Inlet valve" all that has to be entered, in the inventory, is the relay output it is connected to.

A security switch can be activated. This can be linked to one if the available inputs, and it can be set if the switch is "normally closed" or "normally opened".

For more information, see § 5.1 "Inventory" on page 12.



6.1.3. Concentrate valves

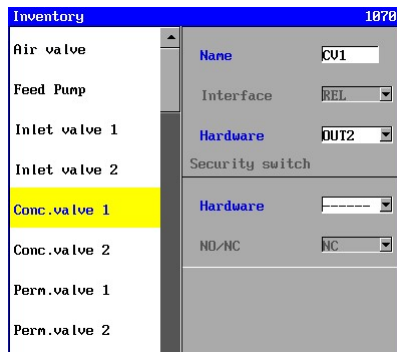

In the case of the “Concentrate valve” all that has to be entered, in the inventory, is the relay output it is connected to.

A security switch can be activated. This can be linked to one if the available inputs, and it can be set if the switch is “normally closed” or “normally opened”.

For more information, see § 5.1 “Inventory” on page 12.

6.1.4. Permeate valves

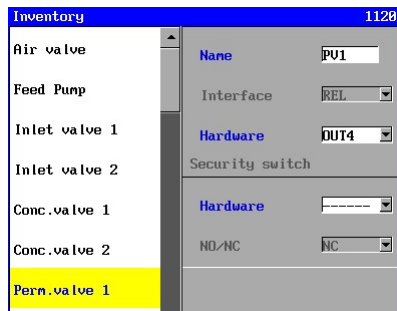

In the case of the “Permeate valve” all that has to be entered, in the inventory, is the relay output it is connected to.

A security switch can be activated. This can be linked to one if the available inputs, and it can be set if the switch is “normally closed” or “normally opened”.

For more information, see § 5.1 “Inventory” on page 12.

If a permeate valve is linked to the level in the permeate tank, then the valve will be opened or closed depending on the level in the permeate tank and the setting (“Open” or “Closed” in a full tank) during the “Filtration” phase, if the valve is activated during this phase.

During all other phases (other than “Filtration”), the valve will immediately be opened or closed at the beginning of the phase, depending on the setting for the respective phase.

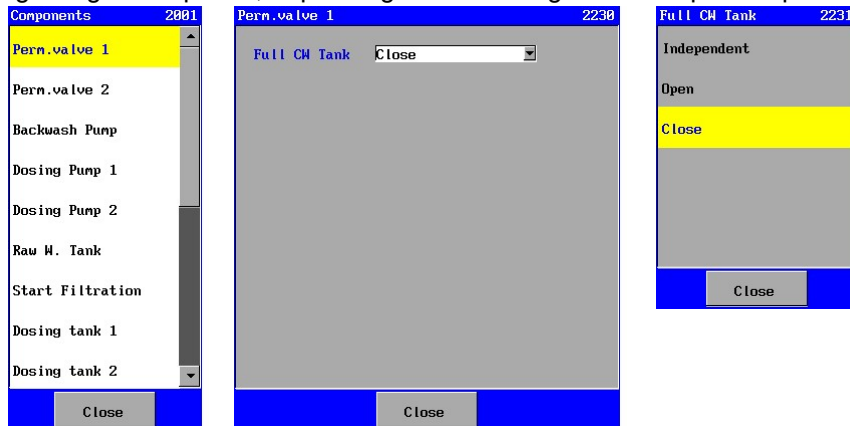

If the permeate valve is not linked to the level in the permeate tank (“Independently”), then the valve will be opened or closed immediately at the beginning of the phase, depending on the setting for the respective phase.

6.1.5. Backwash valve

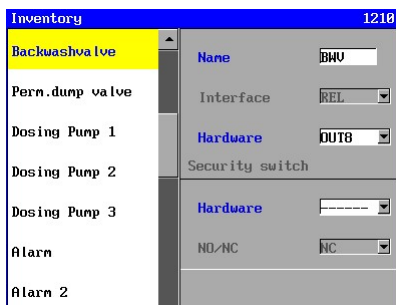

In the case of the “Backwash valve” all that has to be entered, in the inventory, is the relay output it is connected to.

A security switch can be activated. This can be linked to one if the available inputs, and it can be set if the switch is “normally closed” or “normally opened”.

For more information, see § 5.1 “Inventory” on page 12.

6.1.6. Permeate dump valve

Inventory		1228
Backwash valve	Name	DDU
Permeate dump valve	Interface	REL
Dosing Pump 1	Hardware	OUT11
Dosing Pump 2	Security switch	
Dosing Pump 3	Hardware	
Alarm	NO/NC	NC
Alarm 2		

In the case of the “Permeate dump valve” all that has to be entered, in the inventory, is the relay output it is connected to.

A security switch can be activated. This can be linked to one if the available inputs, and it can be set if the switch is “normally closed” or “normally opened”.

For more information, see § 5.1 “Inventory” on page 12.

6.2. Pumps

The pumps may be connected only to the relay outputs (OUTx). Furthermore, a circuit breaker can be activated for the particular pump and in the case of the feed pump and the backwash pump, an analogue output can also be activated to, for example, regulate the control of the pump, by means of a frequency regulator § 5.1 “Inventory” on page 12) per process step, if a pump is switched on or off. If an analogue output has been activated, then in the settings of the processes (see § 5.1 “Inventory” on page 12) it can be set to what percentage of the current range (0-20mA or 4-20mA) the output current must be set to. If a percentage of 0% is entered, then the relevant relay output will be switched off; at a different value the relay output is also activated.

This output in a frequency converter can, for instance, be used as a “target value”. The flow or pressure that must be regulated can, via the “recorder function”, also be directed to the frequency regulator.

There are settings in addition to the inventory settings for the backwash pump and the dosage pump.

6.2.1. Feed pump

Inventory		1848
Air valve	Name	FP
Feed Pump	Interface	REL
Inlet valve 1	Hardware	OUT5
Inlet valve 2	Security switch	
Conc. valve 1	Hardware	IN1
Conc. valve 2	NO/NC	NC
Permeate valve 1	Current Output	
Permeate valve 2	Hardware	OUT-mA1
Backwash Pump	Current	0-20mA

Close

In the case of the “Feed pump” all that has to be entered, in the inventory, is the relay output it is connected to.

A security switch can be activated. This can be linked to one if the available inputs, and it can be set if the switch is “normally closed” or “normally opened”.

An analogue output can furthermore be selected with which, for example, a frequency regulator can be set.

For more information, see § 5.1 “Inventory” on page 12.

6.2.2. Backwash pump

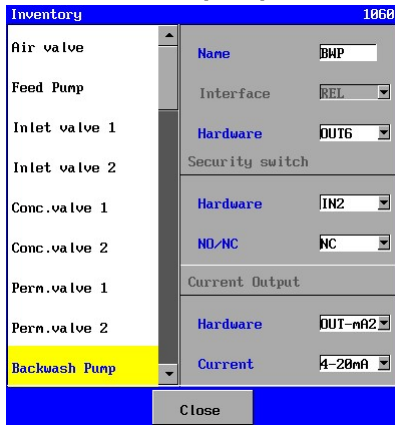

In the case of the “Backwash pump” all that has to be entered, in the inventory, is the relay output it is connected to.

A security switch can be activated. This can be linked to one if the available inputs, and it can be set if the switch is “normally closed” or “normally opened”.

An analogue output can furthermore be selected with which, for example, a frequency regulator can be set.

For more information, see § 5.1 “Inventory” on page 12.

It can be indicated if the backwash pump is dependent on the level in the permeate tank. If it depends on the level in the permeate tank, then the backwash pump will be turned off if the permeate tank is empty.

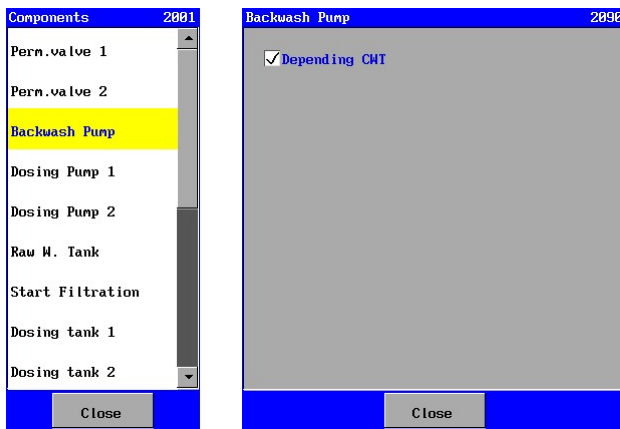

6.2.3. Dosing pumps

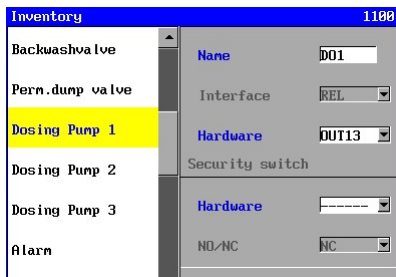

In the case of the “Dosing pump” all that has to be entered, in the inventory, is the relay output it is connected to.

A security switch can be activated. This can be linked to one if the available inputs, and it can be set if the switch is “normally closed” or “normally opened”.

For more information, see § 5.1 “Inventory” on page 12.

The subsequent programming of the dosing pump allows a dosing time to be set between 0 and 9999 (seconds or minutes). When a dosing time of 0 is entered the dosing pump is switched on until the end of the phase.

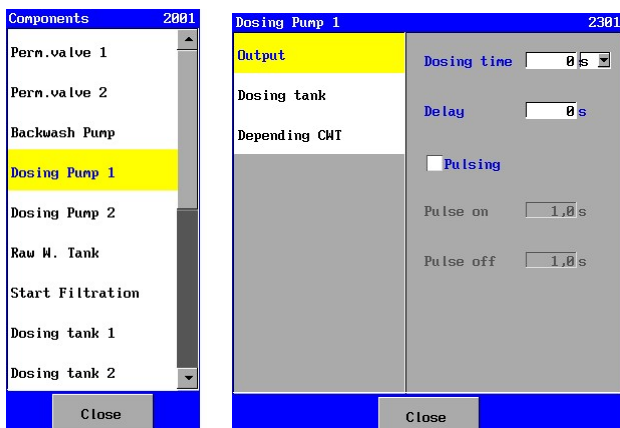

The controls of the dosing pump (“Output”) can be adjusted and connected to a dosing tank in the programming of the dosing pump.

The dosing pump can be switched on with a delay, after the start of the phase. A delay of 0 to 9999 seconds can be entered.



Attention!

If the dosing pump is activated in successive phases (such as phase 1 to phase 2 or from the “Filtration” phase to the “Backwash” phase), the switch-on delay and dosing time will not be reset during the start of next phase.

See § 7 “UF Unit” on page 45 for the activation of the dosing pump during the phases.

For example: § 7.1 UF Unit – Filtration – Phase 1 – Dosing pump.

A pulse function can also be defined.

During the set dosing time pulses are provided as set (“Pulse on”: 0.5 – 999.9 seconds / “Pulse off”: 0.5 – 999.9 seconds).

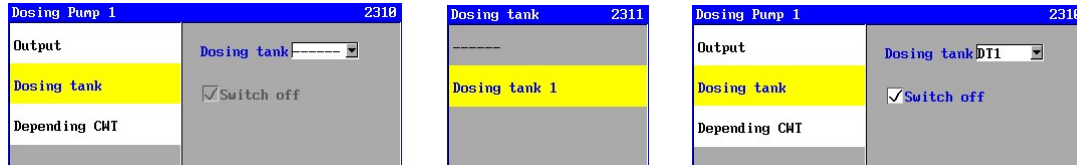

You can connect the proportioning pump to a dosing tank.

You can indicate the connection in this menu and also whether the proportioning pump needs to be turned off when the dosing tank detects a low level.

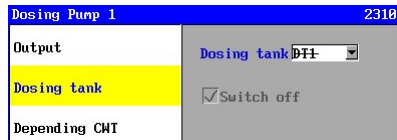

If no level switch is connected to an input (IN1 to IN24) for the selected dosing tank in the inventory, then the text will be crossed out. Since the dosing tank is no longer valid, the dosing pump will no longer depend on the selected dosing tank. The settings will no longer be relevant and will therefore not be displayed.

It can be indicated if the dosing pump is dependent on the level in the permeate tank.

If it depends on the level in the permeate tank, then the dosing pump will be turned off if the permeate tank is empty.



6.3. Alarm



An alarm output may be connected only to a relay output function (OUTx). Activation of the relay is completely independent of the phase the unit is in.

In the case of the “Alarm output” all that has to be entered, in the inventory, is the relay output it is connected to.

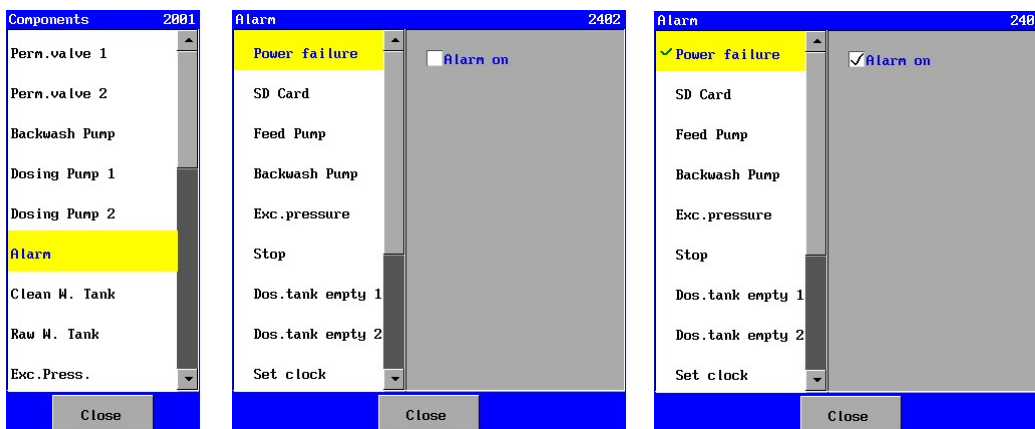

The situation in which the output is activated can be set in the alarm output-related programming.

If a component is not connected or a monitoring is not activated (such as minimum flow monitoring) the monitoring will not appear in this alarm overview list either.

If the monitoring is activated, a check mark ✓ will be shown in front of the corresponding monitoring in the list.

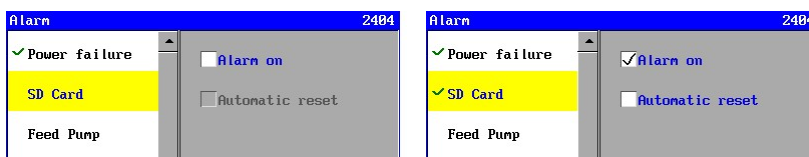

If a monitoring is activated (“Alarm on”), you may choose to switch the alarm output off again automatically (“Automatic reset”), if the alarm situation is removed.

In some cases there is no point in automatically switching off the alarm output nor is there any need to do so. Examples of this are a power failure or maintenance, when the option for an automatic cut-out is not displayed.

The alarm output may also be switched off manually. See § 8 “Alarms” on page 54 or via an external switch where appropriate. See § 6.4.5 “Alarm reset” on page 25.

Attention!

Alarm messages “ROM settings” and “Default settings”.

An alarm is always given when there is a fault in the configuration file. This cannot be set.

In that case the controller has to be reset or a back-up has to be loaded via the boot software.

See § 19 “Hard disk” on page 83 and § 27 “Boot software” on page 104.



6.4. Switches

Switches (e.g. level switches) may be connected only to the digital inputs (IN1 to IN8) (IN9 - IN16, when circuit board cb-8in (1) present, IN17 - IN24, when circuit board cb-8in (2) present). Furthermore, a number of switches can be determined, for each process step.

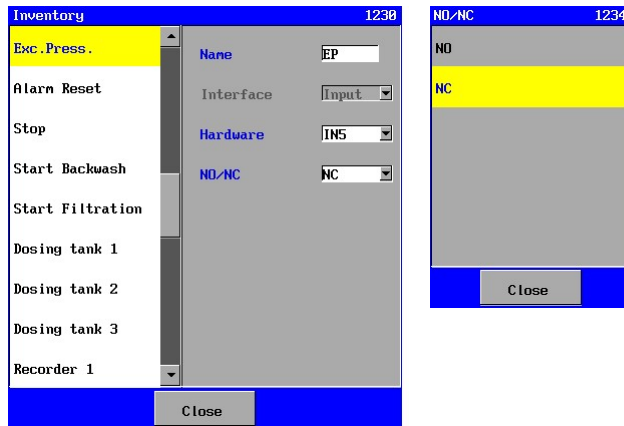

In the case of the switches, the input this is connected to also has to be entered in the inventory.

Whether the switch "is "normally closed (NC)" or "normally open (NO)" also has to be entered.

Example for a "Exceeded pressure" switch.

All switches have other settings on top of the inventory settings, such as a delay on the monitoring. An examination is made in following sections of what the function of the switches is, how the controller will react and what settings are available.

If a monitoring on a switch is switched on during a process the process will be controlled during this time and if the switch is still active after a delay (that can be set) the unit is switched off. The exception to this is the "Alarm reset" switch. This does not affect the process but only the alarms.

Attention!

The switches in the storage tank (high and low level) are not covered here. These correspond to the "Storage tank" component.

6.4.1. Exceeded pressure

The "Exceeded pressure" switch may be placed at a position where an overpressure has to be controlled.

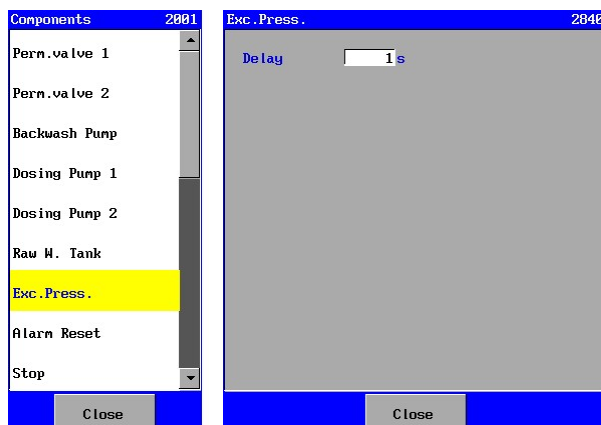

If the unit is switched off after an overpressure situation these can only be switched on again manually.

For information about the inventory see § 6.4 "Switches" on page 23.

A further delay may be entered (0-9999 seconds) for the monitoring.

6.4.2. Stop

The “Stop” switch function may be used for various purposes.

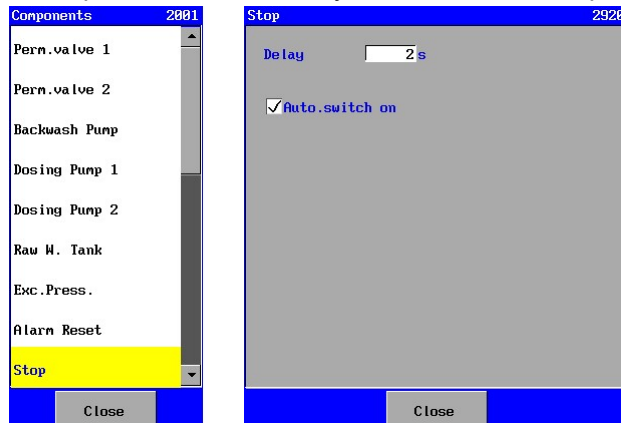

The programming can be set to show if the unit has to be switched on automatically or manually, when the malfunction has been remedied.

For information about the inventory see § 6.4 “Switches” on page 23.

A further delay can be entered (0-9999 seconds) for monitoring. It can also be specified if the unit is automatically switched on, when the malfunction has been remedied, or the unit has to be switched on manually.

6.4.3. Filtration start

With the aid of the “Start Filtration” switch it can be indicated that the “Filtration” phase can be started. For this purpose, it must be specified in the properties of the UF installation that the switching on and off of the installation is dependent on this switch.

See § 7.1 “Properties” on page 45 for more information.

The filtration is only started if no unrefined water tank has been defined or if the unrefined water tank is not empty.

If the switch is not activated anymore, the installation will revert again to the “Standby” phase.

For information about the inventory see § 6.4 “Switches” on page 23.

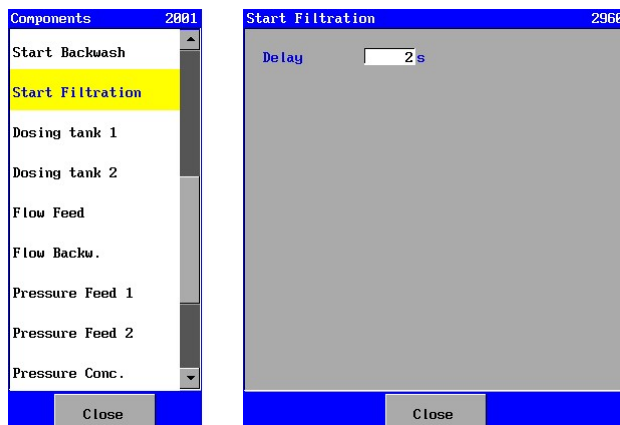

A further delay can be entered (0-9999 seconds) for monitoring.

This feature can be used, for example, for the level in a 2nd storage tank.

In combination with the permeate valves (see § 6.1.4 “Permeate valves” on page 18) it can first be ensured that the storage tank is filled for backwashes and then that the storage tank of the customer is filled.



6.4.4. Start backwash

The “Start backwash” switch can be used to start a backwash.

For information about the inventory see § 6.4 “Switches” on page 23.

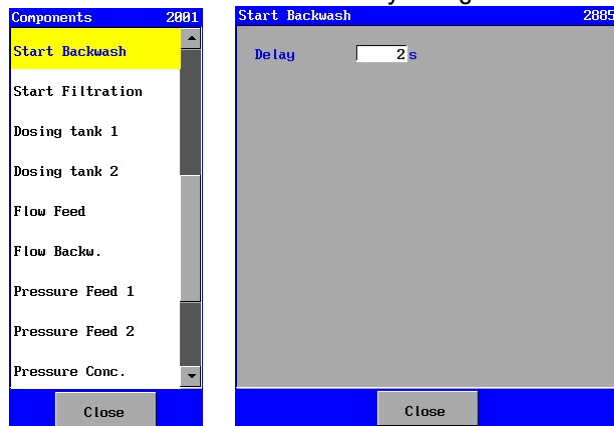

A further delay can be entered (0-9999 seconds) for monitoring.

6.4.5. Alarm reset

The “Alarm reset” switch can be used for an alarm output to be switched off remotely.

The switch does not affect the unit's process run.

For information about the inventory see § 6.4 “Switches” on page 23.

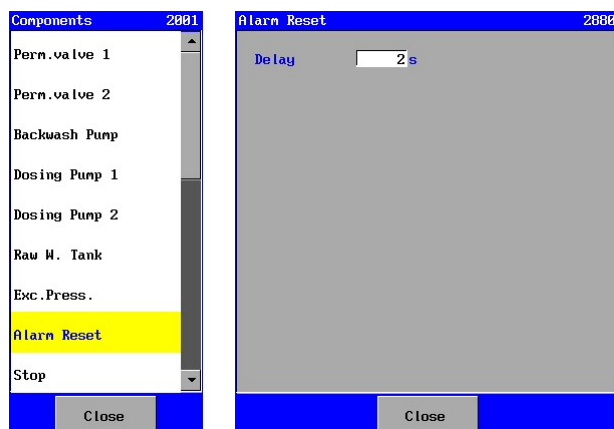

A further delay can be entered (0-9999 seconds) for monitoring.



6.5. Tanks

6.5.1. Clean water tank

There are two available types of level measuring, namely measurements with level switches (1 or 2) or level measurements with a 0(4)-20mA output that can be connected to a 0-20mA control input (if available).

Take note:

The following description assumes that the unrefined water tank is not empty. If the unrefined water tank is empty, then the control will not go to the “Filtration” phase, but will switch to the “Standby” phase (possibly through a backwash, if activated).

Level switches

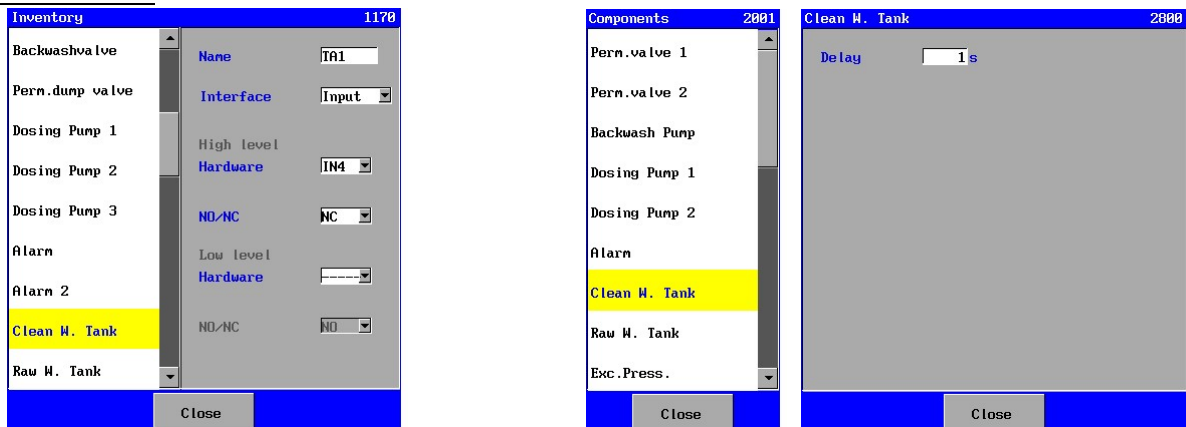

If the level switches are being used, the “Interface Input” will have to be specified.

Two level switches may be placed in a clean water tank. A high-level switch (HL) and a low-level switch (LL). For the inventory the level switch that is connected can be indicated.

If both level switches are not connected the unit may only be switched manually in the “Filtration” phase.

If both switches are connected the unit will be switched in the “Filtration” phase as soon as the low-level switch is active. The unit will quit the “Filtration” phase again as soon the high-level switch is active.

If both switches are active (owing to a faulty connection, cable cut or defect in one of the switches) the high-level switch has the highest priority and the unit will switch off.

If only a high-level switch is programmed, the clean water tank programming can be used to set a delay before the unit is switched on in the “Filtration” phase. If the high-level switch is active the unit will move directly out of the “Filtration” phase. In all other cases no delay has to be set while the clean water tank does not appear in the list of components with programmable settings.

Level measurements 0(4)-20mA output

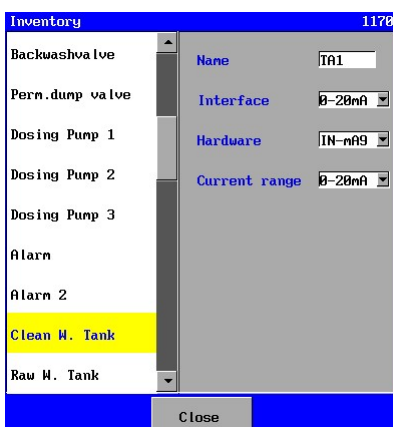

If level measuring with power output is active, the “0-20mA Interface” will be selected.

It will subsequently be possible to select a 0-20mA input. And after that, it will be possible to select the range of the measurement cell (0-20mA or 4-20mA).

If no hardware connection is made, it will only be possible to switch the installation on and off manually.

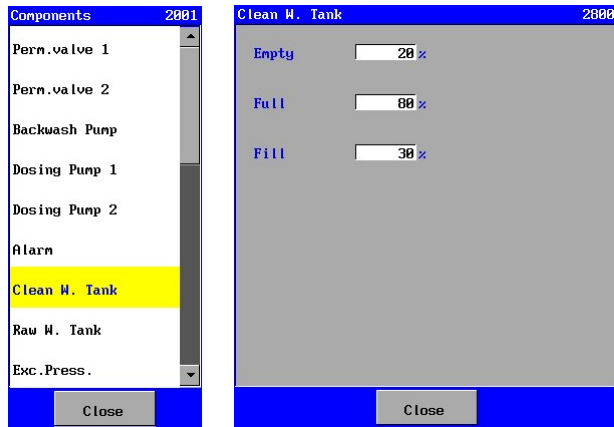

As far as level measuring is concerned, the percentage with empty tank, the percentage with full tank and the percentage for refilling the tank can be specified.

The installation will enter the “Filtration” phase as soon as the percentage goes below the level of the one specified for filling the tank. It will leave the “Filtration” phase as soon as the percentage level reaches higher than the level specified for a full tank.

6.5.2. Raw water tank

There are two available types of level measuring, namely measurements with level switches (1 or 2) or level measurements with a 0(4)-20mA output that can be connected to a 0-20mA control input (if available).

Take note:

The following description assumes that the start of the “Filtration” phase is not blocked by a full storage tank, or by the position of an eventual “Start filtration” switch.

Level switches

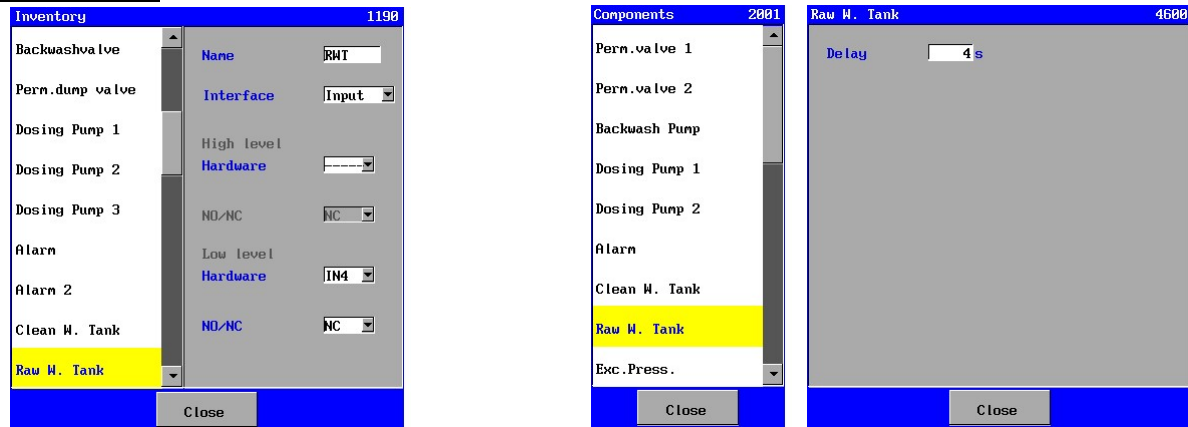

If the level switches are being used, the “Interface Input” will have to be specified.

Two level switches may be placed in a raw water tank. A high-level switch (HL) and a low-level switch (LL). For the inventory the level switch that is connected can be indicated.

Should the two level switches not be connected, then the installation can be switched on via the level in the storage tank, the position of the “Start filtration” switch or through manual operation in the “Filtration” phase

If both switches are connected the unit will be switched in the “Filtration” phase as soon as the low-level switch is not active. The unit will quit the “Filtration” phase again as soon the high-level switch is active.



If only a low-level switch is programmed, the raw water tank programming can be used to set a delay before the unit is switched on in the “Filtration” phase. If the low-level switch is active the unit will move directly out of the “Filtration” phase. In all other cases no delay has to be set while the raw water tank does not appear in the list of components with programmable settings.

Level measurements 0(4)-20mA output

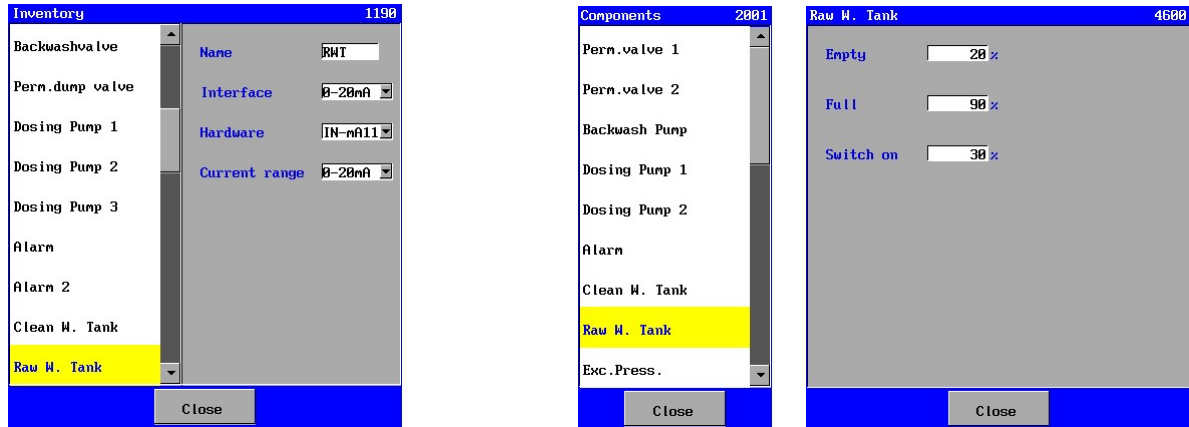

If level measuring with power output is active, the “0-20mA Interface” will be selected.

It will subsequently be possible to select a 0-20mA input. And after that, it will be possible to select the range of the measurement cell (0-20mA or 4-20mA).

If no hardware connection is made, it will only be possible to switch the installation on and off manually.

As far as level measuring is concerned, the percentage with empty tank, the percentage with full tank and the percentage for starting the filtration, can be specified.

The installation will enter the “Filtration” phase as soon as the percentage of the tank goes above the level of the one specified for switching on the installation. The “Filtration” will be left if the level goes below the level of the one specified for an empty tank.

6.5.3. Dosing tank

There are two available types of level measuring, namely measurements with a level switch or level measurements with a 0(4)-20mA output that can be connected to a 0-20mA control input (if available).

Level switch

It is possible to have one level switch in a dosing tank (low level).

Please indicate at which exit the level switch should be connected during the inventory.

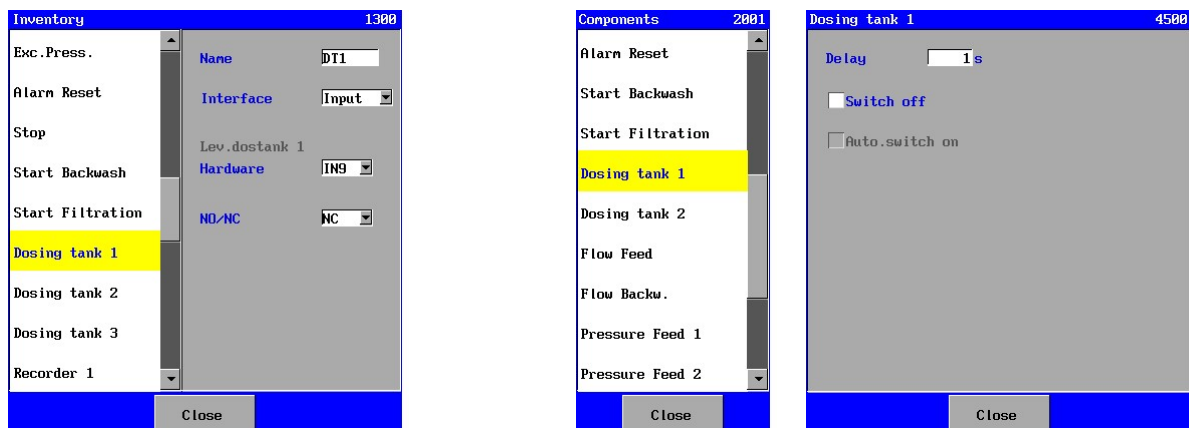



You can secure the low-level switch by entering a delay of 0-9999 seconds. Also, it is possible to indicate whether the unit must be switched off when the level in the dosing tank is too low. When the unit is turned off, you can have the unit turn on automatically when the dosing tank is filled up to a sufficient level.

Level measurements 0(4)-20mA output

The screenshot shows the 'Inventory' window with a list of components on the left and configuration fields on the right. 'Dosing tank 1' is selected and highlighted in yellow. The configuration fields are:

- Name: DT1
- Interface: 0-20mA
- Hardware: IN-mA10
- Current range: 0-20mA

A 'Close' button is located at the bottom of the window.

If level measuring with power output is active, the “0-20mA Interface” will be selected.

It will subsequently be possible to select a 0-20mA input. And after that, it will be possible to select the range of the measurement cell (0-20mA or 4-20mA).

The first screenshot shows the 'Components' window with 'Dosing tank 1' selected. The second screenshot shows the 'Dosing tank 1' configuration window with the following settings:

- Empty: 20 %
- Full: 80 %
- Switch off:
- Auto.switch on:

Both windows have a 'Close' button at the bottom.

As far as level measuring is concerned, the percentage with empty dosage tank and the percentage with full dosage tank can be specified.

Also, it is possible to indicate whether the unit must be switched off when the level in the dosing tank is too low. When the unit is turned off, you can have the unit turn on automatically when the dosing tank is filled up to a sufficient level.

6.6. Recorder outputs

Through optional prints (ca-3rec), three or six recorder outputs (0-20mA) can be added. If the print is connected, then the recorder functions will be displayed in the inventory list.(Recorder 1,2,3,4,5 and 6)

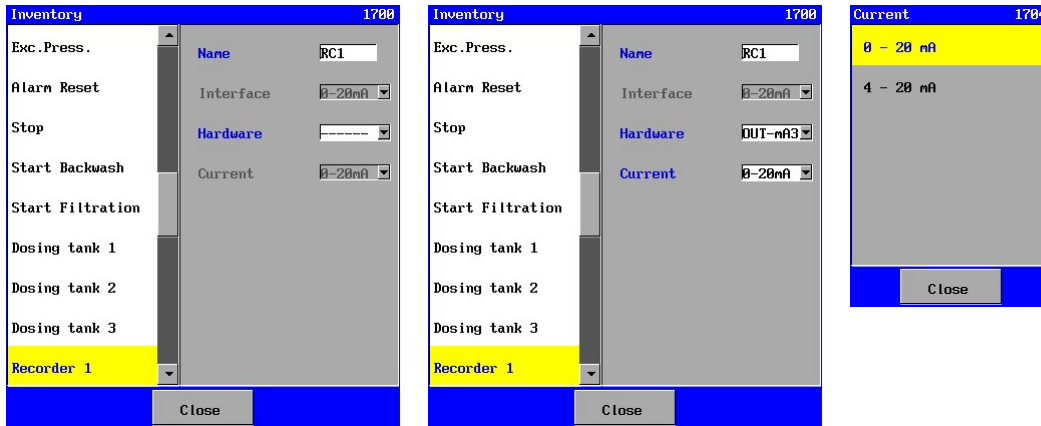

Each output can be set separately within a range of 0-20mA or 4-20mA. Which signals are to be transmitted at the output concerned can be specified next.

All the measured values (e.g. temperature, flow and pressure) can be transmitted to the 0-20mA output.

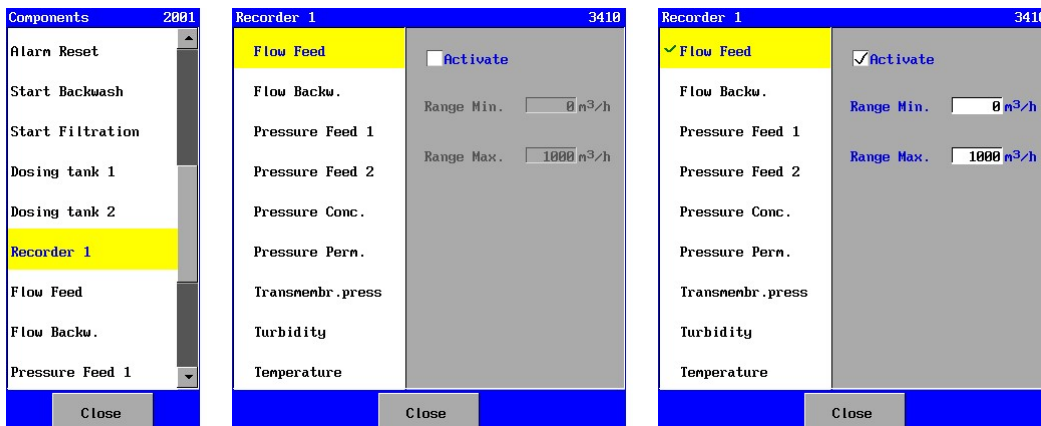

“Activate” must be checked in order to transmit a signal. Next, a range can be specified by entering a minimum and a maximum value. If the measured value of the measurement concerned is lower than (or equal to) the set minimum value, then a current of 0 mA (if the output is set at a current range of 0-20mA) or of 4 mA (if the output is set at a current range of 4-20mA) will be transmitted. If the measured value is higher than (or equal to) the set maximum value, then the output current is 20 mA. If the measured value is within the set measuring range, then the output current will be calculated. The characteristic has a linear coherence.

If a signal is transmitted, then the signal concerned will be checked in the list of the recorder output concerned.



6.7. Flow meter

The flow meters equipped with a 0(4)-20mA output can be connected to the control panel.

It is possible to specify thresholds for the upper and lower limits, both with a programmable time delay.

It is also possible to specify whether the installation should be shut down in case of either positive or negative crossing of the specified values.

If the thresholds are activated, it is possible to send an alarm message when, for instance, the upper threshold is exceeded (this can be either through a relay or with an e-mail (only possible with UFS8x1x-xxxx)).

The properties of the flow meters are only visible if the control panel is equipped with prints with 0-20mA inputs (ca-fl-pr-3an).

6.7.1. Flow Feed

This meter indicates the flow for the incoming water.

The way of editing flow measurements is described in § 6.7.5 “Flow meter settings” on page 32.

6.7.2. Flow Permeate 1

This meter indicates the flow for the permeate water.

The way of editing flow measurements is described in § 6.7.5 “Flow meter settings” on page 32.

With the inventory, the screen number needs to be increased by 10 each time.

With programming the screen number needs to be increase by 20 each time.

6.7.3. Flow Permeate 2

This meter indicates the flow for the permeate water.

The way of editing flow measurements is described in § 6.7.5 “Flow meter settings” on page 32.

With the inventory, the screen number needs to be increased by 20 each time.

With programming the screen number needs to be increase by 40 each time.

6.7.4. Flow Backwash

This meter indicates the flow for the backwash water.

The way of editing flow measurements is described in § 6.7.5 “Flow meter settings” on page 32.

With the inventory, the screen number needs to be increased by 30 each time.

With programming the screen number needs to be increase by 60 each time.



6.7.5. Flow meter settings

This description cites the properties of flow measurement in the feed water as an example. Similar properties apply for other flow measurements.

The 0-20mA input that is connected to the concerned flow meter can be selected for the inventarisation.

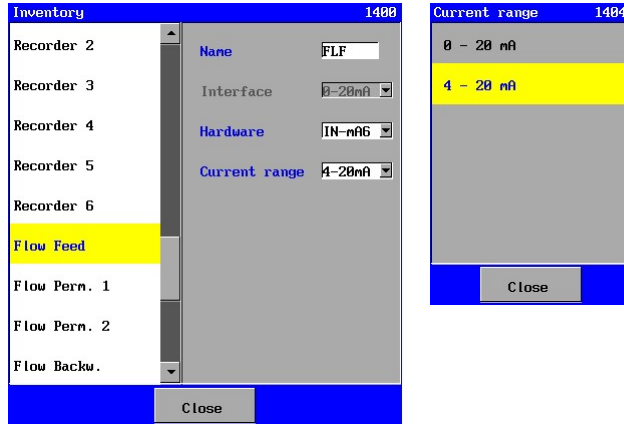

The current range of the flow meter also has to be specified (0-20mA or 4-20mA).

6.7.6. Properties flow meter

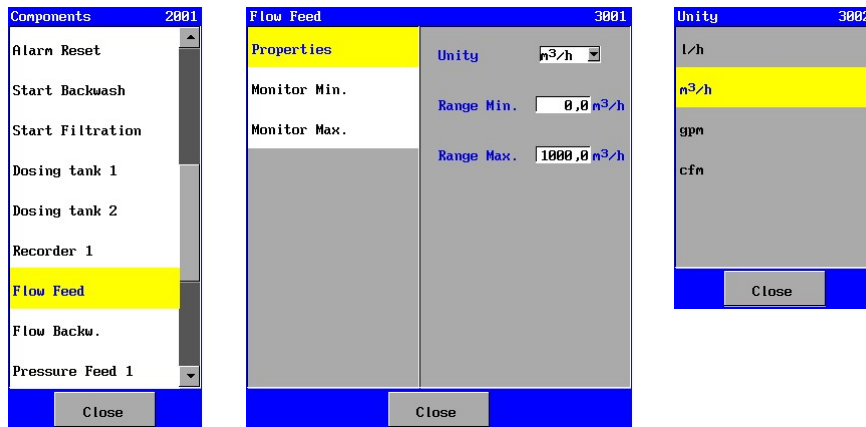

In this window you can set in which unity the measurement value should be displayed. Furthermore, the measuring range of the measuring cell can be specified. Measured flow with minimal current ("Range Min." between 0,0 and 10.000,0) and measured flow with maximal current ("Range Max." between 0,0 and 10.000,0). We consider that there is a linear characteristic between the current and the measured flow for these measurements.



6.7.7. Monitoring minimum flow

For monitoring purposes the minimum limit of 0,1 to 10.000,0 can be entered.

The image shows two side-by-side screenshots of the 'Flow Feed' dialog box for unit 3010. Both screenshots have a blue title bar with 'Flow Feed' and '3010'. The left screenshot has the 'Monitor' checkbox unchecked, and the 'Monitor Min.' field is highlighted in yellow. The right screenshot has the 'Monitor' checkbox checked, and the 'Monitor Min.' field is highlighted in yellow. Both screenshots show a 'Limit' of 1,0 m³/h and a 'Delay' of 10 s. A 'Switch off' checkbox is also present in both.

A delay can also be entered (1-9999 sec). During the delay the measured value has to be under the limit so an alarm is given if the unit is switched off.

You can set if the unit actually is switched off ("Switch off").

If the monitoring is not switched on ("Monitor") the monitoring will not appear in the programming list of phases.

6.7.8. Monitoring maximum flow

For monitoring purposes the maximum limit of 0,1 to 10.000,0 can be entered.

The image shows two side-by-side screenshots of the 'Flow Feed' dialog box for unit 3015. Both screenshots have a blue title bar with 'Flow Feed' and '3015'. The left screenshot has the 'Monitor' checkbox unchecked, and the 'Monitor Max.' field is highlighted in yellow. The right screenshot has the 'Monitor' checkbox checked, and the 'Monitor Max.' field is highlighted in yellow. Both screenshots show a 'Limit' of 100,0 m³/h and a 'Delay' of 5 s. A 'Switch off' checkbox is also present in both.

A delay may also be entered (1-9999 sec). During the delay the measured value has to be under the limit so an alarm is given if the unit is switched off.

You can set if the unit is actually switched off ("Switch off").

If the monitoring is not switched on ("Monitor") the monitoring will not appear in the programming list of phases.



6.8. Pressure meter

The pressure meters equipped with a 0(4)-20mA output can be connected to the control panel. It is possible to specify thresholds for the upper and lower limits, both with a programmable time delay. It is also possible to specify whether the installation should be shut down in case of either positive or negative crossing of the specified values.

If the thresholds are activated, it is possible to send an alarm message when, for instance, the upper threshold is exceeded (this can be either through a relay or with an e-mail (only possible with UFS8x1x-xxxx)).

The properties of the pressure meters are only visible if the control panel is equipped with prints with 0-20mA inputs (ca-fl-pr-3an).

6.8.1. Pressure Feed 1

This meter indicates the pressure in the feed pipe.

The way of editing flow measurements is described in § 6.8.7 "Pressure meter settings" on page 35.

6.8.2. Pressure Feed 2

This meter indicates the pressure in the feed pipe.

The way of editing flow measurements is described in § 6.8.7 "Pressure meter settings" on page 35.

With the inventory, the screen number needs to be increased by 10 each time.

With programming the screen number needs to be increase by 20 each time.

6.8.3. Pressure Backwash

This meter indicates the pressure in the backwash pipe.

The way of editing flow measurements is described in § 6.8.7 "Pressure meter settings" on page 35.

With the inventory, the screen number needs to be increased by 20 each time.

With programming the screen number needs to be increase by 40 each time.

6.8.4. Pressure Air

This meter indicates the pressure in the air pipe.

The way of editing flow measurements is described in § 6.8.7 "Pressure meter settings" on page 35.

With the inventory, the screen number needs to be increased by 30 each time.

With programming the screen number needs to be increase by 60 each time.

6.8.5. Pressure Concentrate

This meter indicates the pressure in the concentrate pipe.

The way of editing flow measurements is described in § 6.8.7 "Pressure meter settings" on page 35.

With the inventory, the screen number needs to be increased by 40 each time.

With programming the screen number needs to be increase by 80 each time.

6.8.6. Pressure Permeate

This meter indicates the pressure in the permeate pipe.

The way of editing flow measurements is described in § 6.8.7 "Pressure meter settings" on page 35.

With the inventory, the screen number needs to be increased by 50 each time.

With programming the screen number needs to be increase by 100 each time.



6.8.7. Pressure meter settings

This description cites the properties of pressure measurement in the feed water as an example. Similar properties apply for other pressure measurements.

The 0-20mA input that is connected to the concerned pressure meter can be selected for the inventarisation.

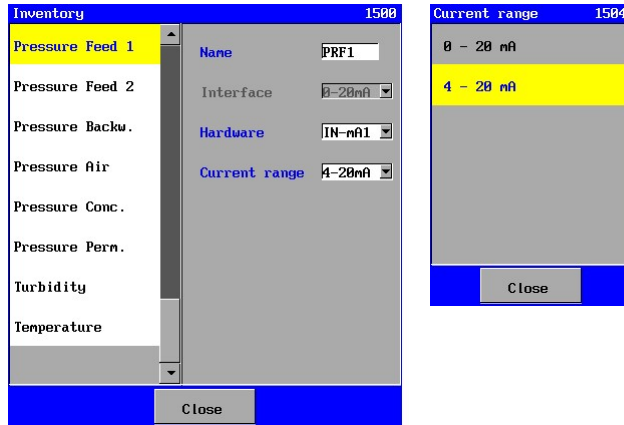

The current range of the pressure meter also has to be specified (0-20mA or 4-20mA).

6.8.8. Properties pressure meter

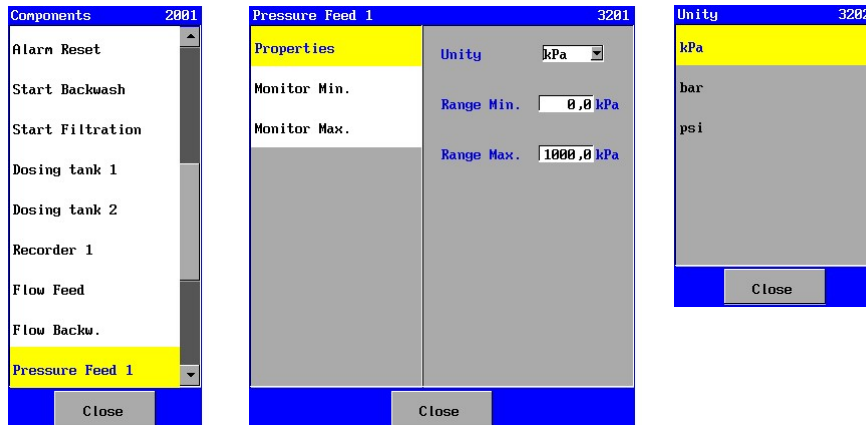

In this window you can set in which unity the measurement value should be displayed. Furthermore, the measuring range of the measuring cell can be specified. Measured pressure with minimal current ("Range Min." between 0,0 and 10.000,0) and measured pressure with maximal current ("Range Max." between 0,0 and 10.000,0). We consider that there is a linear characteristic between the current and the measured pressure for these measurements.



6.8.9. Monitoring minimum pressure

For monitoring purposes the minimum limit of 0.1 to 10.000,0 can be entered.

A delay can also be entered (1-9999 sec). During the delay the measured value has to be under the limit so an alarm is given if the unit is switched off.

You can set if the unit actually is switched off ("Switch off").

If the monitoring is not switched on ("Monitor") the monitoring will not appear in the programming list of phases.

6.8.10. Monitoring maximum pressure

For monitoring purposes the maximum limit of 0.1 to 10.000,0 can be entered.

A delay may also be entered (1-9999 sec). During the delay the measured value has to be under the limit so an alarm is given if the unit is switched off.

You can set if the unit is actually switched off ("Switch off").

If the monitoring is not switched on ("Monitor") the monitoring will not appear in the programming list of phases.



6.9. Turbidity meter

A turbidity meter equipped with a 0(4)-20mA output can be connected to the control panel. It is possible to specify thresholds for the upper and lower limits, both with a programmable time delay. It is also possible to specify whether the installation should be shut down in case of either positive or negative crossing of the specified values. If the thresholds are activated, it is possible to send an alarm message when, for instance, the upper threshold is exceeded (this can be either through a relay or with an e-mail (only possible with UFS8x1x-xxxx)).

The settings for the turbidity measurement are visible only when the controller is equipped with printing with 0-20mA inputs (ca-fl-pr-3an).

6.9.1. Turbidity meter settings

During the inventory, the 0-20 mA input can be selected where the turbidity meter is on.

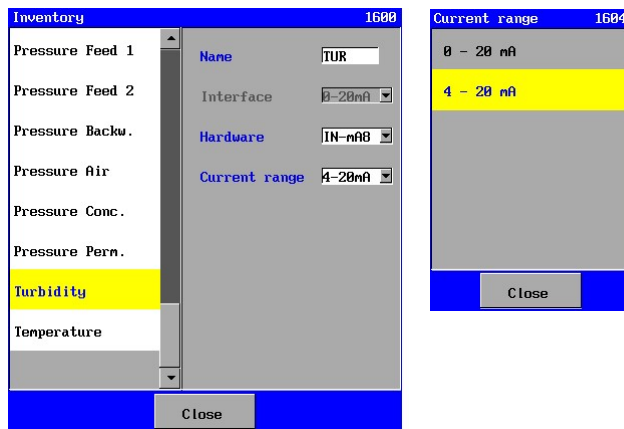

The current range of the turbidity meter also has to be specified (0-20mA or 4-20mA).

6.9.2. Properties turbidity meter

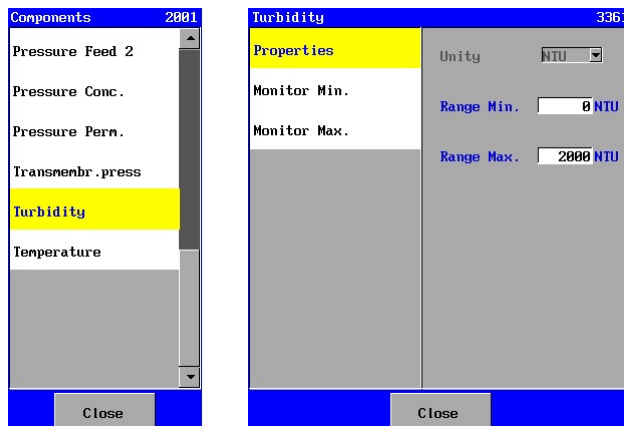

In this window you can set in which unity the measurement value should be displayed. Furthermore, the measuring range of the measuring cell can be specified. Measured turbidity with minimal current ("Range Min." between 0 and 2.500 NTU) and measured turbidity with maximal current ("Range Max." between 0 and 2.500 NTU). We consider that there is a linear characteristic between the current and the measured turbidity for these measurements.



6.9.3. Monitoring minimum turbidity

For monitoring purposes the minimum limit of 1 to 2.500 NTU can be entered.

A delay can also entered (1-9999 sec). During the delay the measured value has to be under the limit so an alarm is given if the unit is switched off.

You can set if the unit actually is switched off (“Switch off”).

If monitoring is enabled here, it will be activated during the “Filtration” phase. This is adjustable. This will automatically be switched off during the other phases.

6.9.4. Monitoring maximum turbidity

For monitoring purposes the maximum limit of 1 to 2.500 NTU can be entered.

A delay may also be entered (1-9999 sec). During the delay the measured value has to be under the limit so an alarm is given if the unit is switched off.

You can set if the unit is actually switched off (“Switch off”).

If monitoring is enabled here, it will be activated during the “Filtration” phase. This is adjustable. This will automatically be switched off during the other phases.



6.10. Temperature

A temperature meter equipped with a 0(4)-20mA output can be connected to the control panel. It is possible to specify thresholds for the upper and lower limits, both with a programmable time delay. It is also possible to specify whether the installation should be shut down in case of either positive or negative crossing of the specified values.

If the thresholds are activated, it is possible to send an alarm message when, for instance, the upper threshold is exceeded (this can be either through a relay or with an e-mail (only possible with UFS8x1x-xxxx)).

The settings for the temperature measurement are visible only when the controller is equipped with printing with 0-20mA inputs (ca-fl-pr-3an).

6.10.1. Temperature meter settings

During the inventory, the 0-20 mA input can be selected where the temperature meter is on.

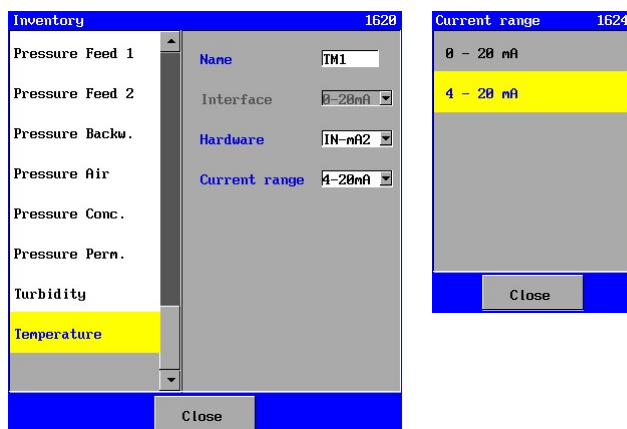

The current range of the temperature meter also has to be specified (0-20mA or 4-20mA).

6.10.2. Properties temperature meter

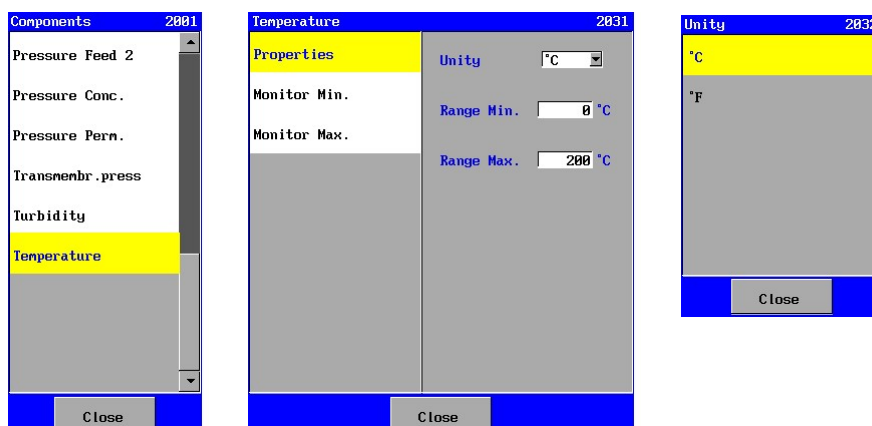

In this window you can set in which unity the measurement value should be displayed. Furthermore, the measuring range of the measuring cell can be specified. Measured temperature with minimal current ("Range Min." between 0 and 200) and measured temperature with maximal current ("Range Max." between 0 and 200). We consider that there is a linear characteristic between the current and the measured temperature for these measurements.



6.10.3. Monitoring minimum temperature

For monitoring purposes the minimum limit of 1 to 200 can be entered.

Temperature	2040
Properties	<input type="checkbox"/> Monitor
Monitor Min.	Limit <input type="text" value="10"/> °C
Monitor Max.	Delay <input type="text" value="2"/> s
	<input type="checkbox"/> Switch off
Close	

Temperature	2040
Properties	<input checked="" type="checkbox"/> Monitor
Monitor Min.	Limit <input type="text" value="10"/> °C
Monitor Max.	Delay <input type="text" value="2"/> s
	<input type="checkbox"/> Switch off
Close	

A delay can also be entered (1-9999 sec). During the delay the measured value has to be under the limit so an alarm is given if the unit is switched off.

You can set if the unit actually is switched off ("Switch off").

If the monitoring is not switched on ("Monitor") the monitoring will not appear in the programming list of phases.

6.10.4. Monitoring maximum temperature

For monitoring purposes the maximum limit of 1 to 200 can be entered.

Temperature	2045
Properties	<input type="checkbox"/> Monitor
Monitor Min.	Limit <input type="text" value="30"/> °C
Monitor Max.	Delay <input type="text" value="3"/> s
	<input type="checkbox"/> Switch off
Close	

Temperature	2045
Properties	<input checked="" type="checkbox"/> Monitor
Monitor Min.	Limit <input type="text" value="30"/> °C
Monitor Max.	Delay <input type="text" value="3"/> s
	<input type="checkbox"/> Switch off
Close	

A delay may also be entered (1-9999 sec). During the delay the measured value has to be under the limit so an alarm is given if the unit is switched off.

You can set if the unit is actually switched off ("Switch off").

If the monitoring is not switched on ("Monitor") the monitoring will not appear in the programming list of phases.



6.11. Transmembrane pressure

The transmembrane pressure can be determined in the controls. This is determined according to the formula:

$$\text{Transmembrane pressure} = ((\text{"Pressure Feed 2"} + \text{"Pressure Concentrate"}) / 2) - \text{"Permeate Pressure"}.$$

It is possible to specify thresholds for the upper and lower limits, both with a programmable time delay. It is also possible to specify whether the installation should be shut down in case of either positive or negative crossing of the specified values.

If the thresholds are activated, it is possible to send an alarm message when, for instance, the upper threshold is exceeded (this can be either through a relay or with an e-mail (only possible with UFS8x1x-xxxx)).

The settings for the transmembrane pressure are visible only if the corresponding measurements are connected to the controllers.

The transmembrane pressure is not on the inventory list, because it is not a direct measurement, but a value calculated from other pressure measurements.

If monitoring for maximum transmembrane pressure is enabled, a backwash can be initiated when the transmembrane pressure is above the programmed limit for the programmed time.

See also § 6.11.3 "Monitoring maximum transmembrane pressure" on page 42.

6.11.1. Properties transmembrane pressure

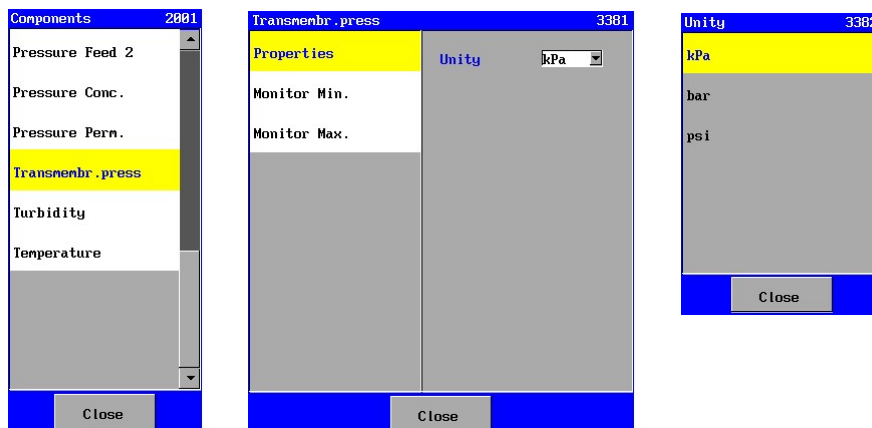

In this window you can set the unit in which the calculated value should be displayed. If a measured pressure, which is used in the calculation, is displayed in another unit, then this measured value is converted to the unit that is set for the transmembrane pressure.



6.11.2. Monitoring minimum transmembrane pressure

For monitoring purposes the minimum limit of 0,1 to 1000,0 can be entered.

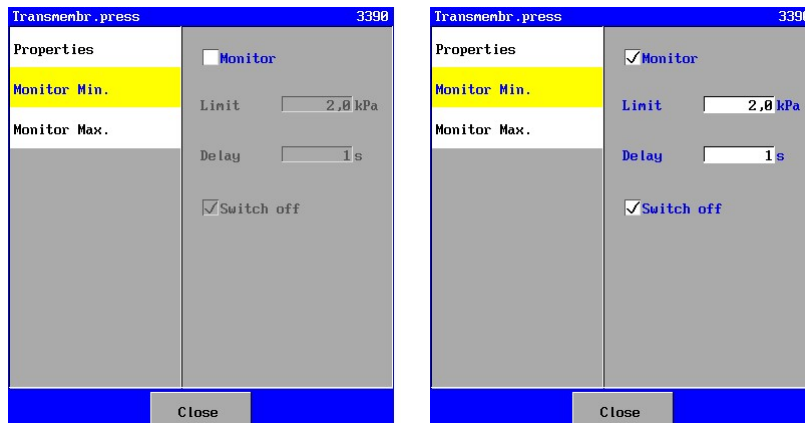

A delay can also be entered (1-9999 sec). During the delay the measured value has to be under the limit so an alarm is given if the unit is switched off.

You can set if the unit actually is switched off ("Switch off").

If monitoring is enabled here, it will be activated during the "Filtration" phase. This is adjustable. This will automatically be switched off during the other phases.

6.11.3. Monitoring maximum transmembrane pressure

For monitoring purposes the maximum limit of 0,1 to 1000,0 can be entered.

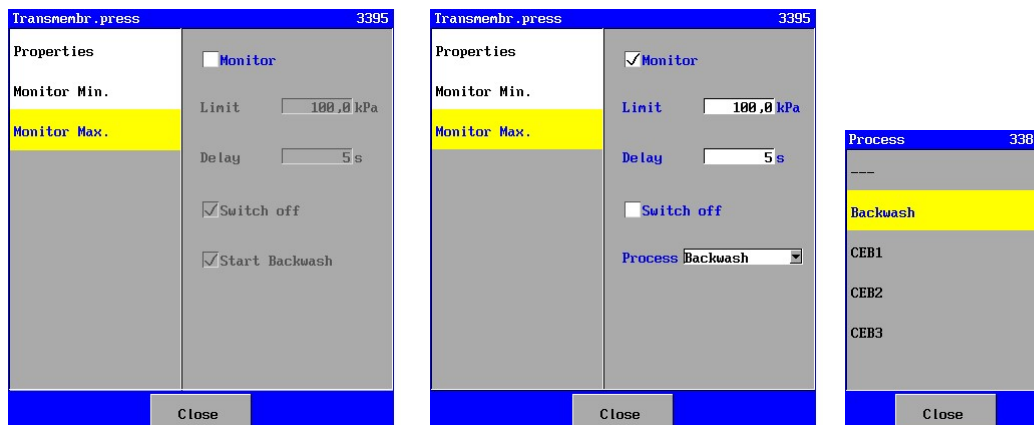

A delay may also be entered (1-9999 sec). During the delay the measured value has to be under the limit so an alarm is given if the unit is switched off.

You can set if the unit is actually switched off ("Switch off").

If monitoring is enabled here, it will be activated during the "Filtration" phase. This is adjustable. This will automatically be switched off during the other phases.

If monitoring is enabled here, a backwash or CEB can be initiated when the transmembrane pressure is above the programmed limit for the programmed time.

After backwashing or CEB, the transmembrane pressure is monitored again and if the calculated pressure is much higher again than within the set delay time + 20 seconds, then an alarm will sound and the controls will be disabled.

Should the transmembrane pressure still be below the maximum limit after 20 seconds, a backwash or CEB will be then started again at the next time the limit value is exceeded.



6.12. pH meter

The pH meters equipped with a 0(4)-20mA output can be connected to the control panel.

It is possible to specify thresholds for the upper and lower limits, both with a programmable time delay.

It is also possible to specify whether the installation should be shut down in case of either positive or negative crossing of the specified values.

If the thresholds are activated, it is possible to send an alarm message when, for instance, the upper threshold is exceeded (this can be either through a relay or with an e-mail (only possible with UFS8x1x-xxxx)).

The properties of the flow meters are only visible if the control panel is equipped with prints with 0-20mA inputs (ca-fl-pr-3an).

6.12.1. pH meter settings

The 0-20mA input that is connected to the concerned pH meter can be selected for the inventarisation.

The screenshot shows two windows. The left window, titled 'Inventory' (ID 1660), has a list of components on the left and configuration fields on the right. 'pH 1' is selected in the list. The configuration fields are: Name: PH1, Interface: 0-20mA, Hardware: IN-mA2, and Current range: 0-20mA. The right window, titled 'Current range' (ID 1664), shows two options: '0 - 20 mA' (highlighted in yellow) and '4 - 20 mA'. Both windows have a 'Close' button at the bottom.

The current range of the pH meter also has to be specified (0-20mA or 4-20mA).

6.12.2. Properties pH meter

The screenshot shows two windows. The left window, titled 'Components' (ID 2801), has a list of components on the left and configuration fields on the right. 'pH 1' is selected in the list. The configuration fields are: Unity: (dropdown menu), Monitor Min.: Range Min. 0,0, and Monitor Max.: Range Max. 20,0. The right window, titled 'pH 1' (ID 3301), shows the 'Properties' dialog box with the same configuration fields as the left window. Both windows have a 'Close' button at the bottom.

The measuring range of the measuring cell can be specified. Measured pH with minimal current ("Range Min." between 0,0 en 14,0) and measured pH with maximal current ("Range Max." between 0,0 and 14,0). We consider that there is a linear characteristic between the current and the measured pH for these measurements.



6.12.3. Monitoring minimum pH

For monitoring purposes the minimum limit of 0,1 to 14,0 can be entered.

A delay can also be entered (1-9999 sec). During the delay the measured value has to be under the limit so an alarm is given if the unit is switched off.

You can set if the unit actually is switched off ("Switch off").

If the monitoring is not switched on ("Monitor") the monitoring will not appear in the programming list of phases.

6.12.4. Monitoring maximum pH

For monitoring purposes the maximum limit of 0,1 to 14,0 can be entered.

A delay may also be entered (1-9999 sec). During the delay the measured value has to be under the limit so an alarm is given if the unit is switched off.

You can set if the unit is actually switched off ("Switch off").

If the monitoring is not switched on ("Monitor") the monitoring will not appear in the programming list of phases.



7. UF Unit

This chapter will examine the various phases of the UF unit.

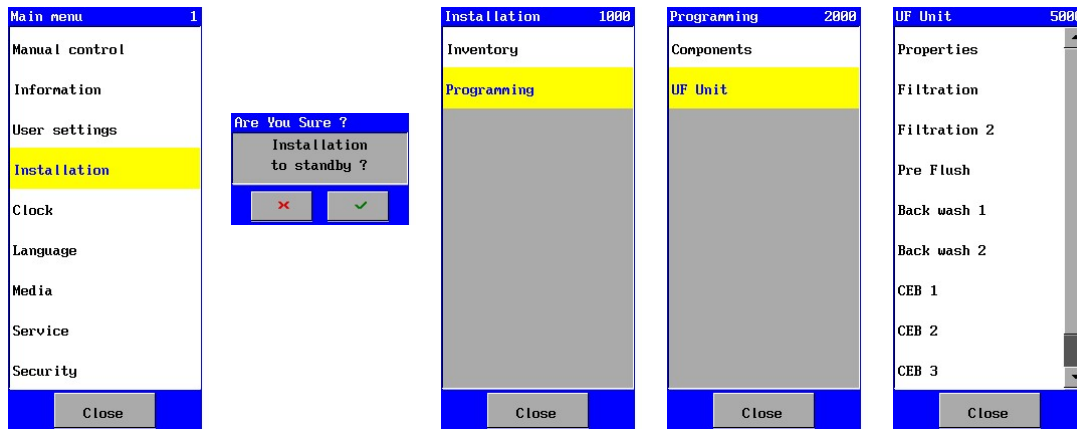

The manual control opportunities are explained in § 9 “Manual operation of the unit” on page 57.

7.1. Properties

The general characteristics with regards to the installation can be set in this window.

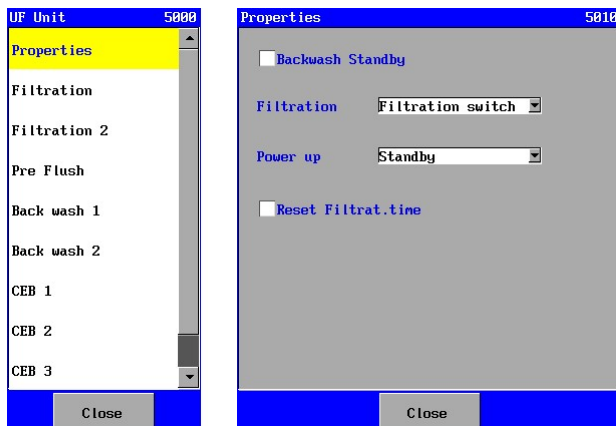

It can be indicated if the installation must carry out another backwash, if the installation is switched off after the “Standby” phase. If two backwashes have been activated, then the backwash will start whose turn it is at that moment.

Once the filtration has been relinquished, it can also be set if the filtration time must be reset (immediately after standby), or once the voltage of the controls has been switched off.

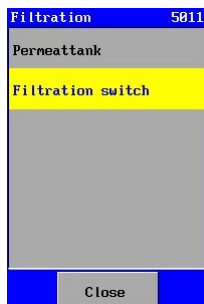

It can further be indicated which component is to be monitored for the switching on and off of the installation (providing that the unrefined water tank is not empty).

This can depend on the level in the storage tank, or dependent on a “Filtration start” switch.

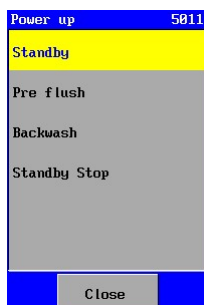

It can be set in which phase the controls must start after a power failure.



7.2. Filtration

During the "Filtration" phase the unit provides treated water: the untreated water generally flows via via the feed pump to the inlet valve and then to the ultra filtration module.

The production of treated water can be launched depending on the level of water in the raw water en clean water tank, depending on the position of the "Filtration start" switch or manually. During production a service hour counter will be kept which can be read off under the menu option "Information" (see § 10.5 "Counters" on page 61). A counter will also be kept in connection with maintenance, if this is programmed (see § 23.2 "Maintenance" on page 95)). This can be read off in the same window as the service hour counter.

It is possible to turn off the installation manually during the "Filtration" phase, irrespective of the position of the level switches in the tank(s), or the position of the "Filtration start" switch. The installation will revert to the "Standby" phase, or to a backwash (if programmed, see § 7.1 "Properties" on page 45).



The "Filtration" phase consists of one step with a duration of each 0-9999 seconds / minutes.

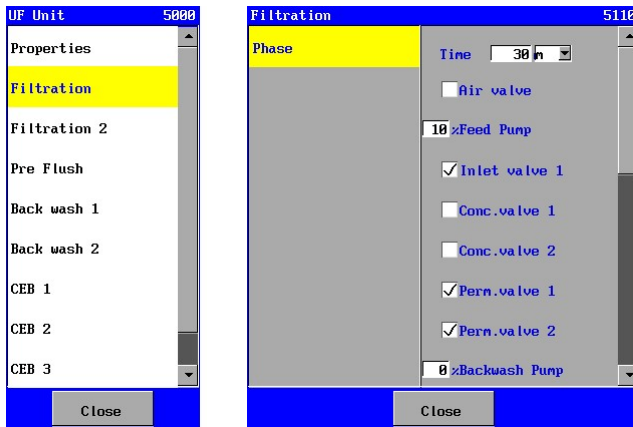

For each stage you can enter what inputs or limits have to be monitored and what outputs have to be activated. A time has to be entered (0-9999 seconds / minutes) in phases 1, 2, 3 and 5. If a time of 0 is entered the corresponding phase will be omitted.

Attention!

A permeate valve can be connected to the level in the storage tank. If the valve is activated during this step, then the valve will be opened or closed, depending on the level in the stock tank and the setting valve in the permeate valve. (zie ook § 6.1.4 "Permeate valves" on page 18).

7.3. Filtration 2

With the phase "Filtration 2" it is possible to perform a "top/bottom" filtration. The filtration cycle will look like this :



or (in case "Backwash 2" is not activated) :



The phase "Filtration 2" is functioning equal to the phase "Filtration".

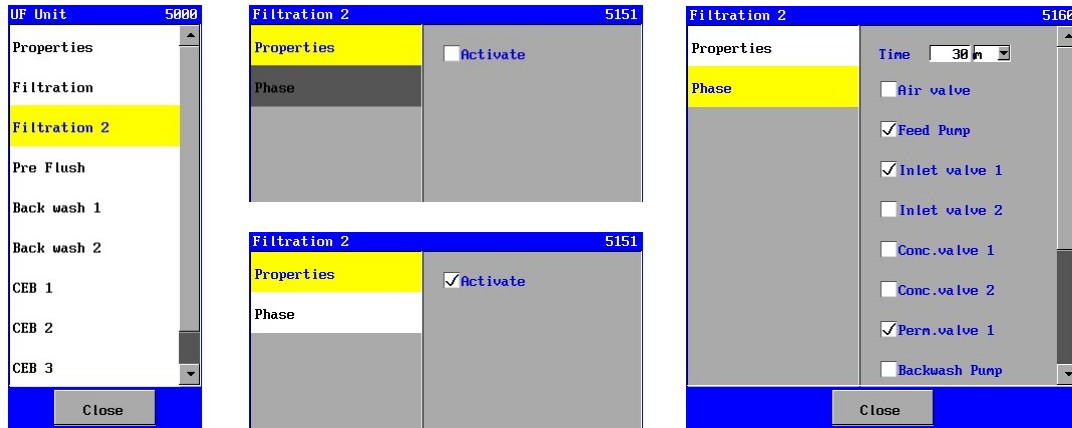

If no 2nd backwash is desired, the phase may be omitted by turning the phase switch off (no check mark in “Activate”). If the phase is activated the various stages can be programmed.

7.4. Pre Flush

The "Pre Flush" phase is used to clean the membrane before going into “Filtration”.
 The “Pre Flush” phase consists of one step with a duration of each 0-9999 seconds / minutes.



If no pre-rinsing is desired for the “Filtration” phase, the phase may be omitted by turning the phase switch off (no check mark in “Activate”). If the phase is activated the various stages can be programmed.

For each stage you can enter what inputs or limits have to be monitored and what outputs have to be activated and the time duration of the phase (0-9999 seconds / minutes).

If a time of 0 is entered the corresponding phase will be omitted.

7.5. Backwash 1

The "Backwash 1" phase is used for a standard backwash cycle. This phase will always be activated and will follow after the phase “Filtration”. Schematically this will look as follows :



The backwash may comprise a max. of 6 stages each with a time duration of 0-9999 seconds /minutes.

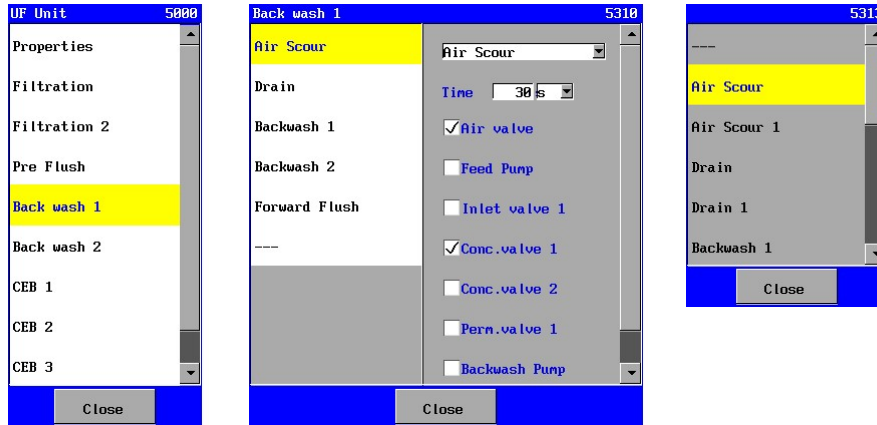

The name of the sub-process can be set. This is because the order of the sub-processes for this phase is not always identical for every installation.

For each step you can enter which inputs of limits are monitored, which outputs have to be activated and the time duration of the phase (0-9999 seconds / minutes).
 If a time of 0 is entered the corresponding phase will be omitted.

7.6. Backwash 2

The "Backwash 2" phase is used for a 2nd backwash cycle. With this you can make a difference for a "bottom" backwash and a "top" backwash. After a "Filtration" the both backwashes will be started alternated. Schematically this will look as follows :



The backwash may comprise a max. of 6 stages each with a time duration of 0-9999 seconds /minutes.



The name of the sub-process can be set. This is because the order of the sub-processes for this phase is not always identical for every installation.

If no 2nd backwash is desired, the phase may be omitted by turning the phase switch off (no check mark in "Activate"). If the phase is activated the various stages can be programmed.

For each step you can enter which inputs of limits are monitored, which outputs have to be activated and the time duration of the phase (0-9999 seconds / minutes).
 If a time of 0 is entered the corresponding phase will be omitted.



7.7. CEB 1

The “CEB 1” phase is used to clean the membrane chemically at adjustable intervals. The backwash may comprise a max. of 11 stages each with a time duration of 0-9999 seconds /minutes.

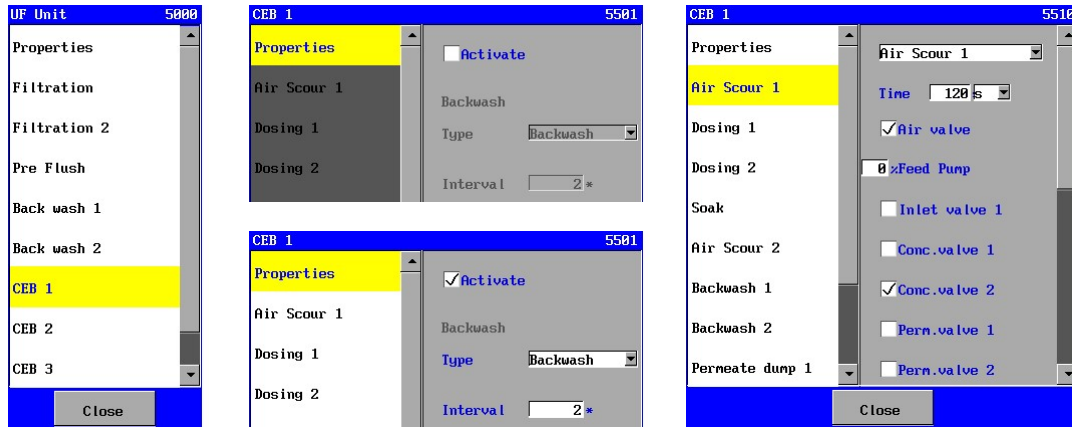

If no backwash is desired, the phase may be omitted by turning the phase switch off (no check mark in “Activate”). If the phase is activated the various stages can be programmed.

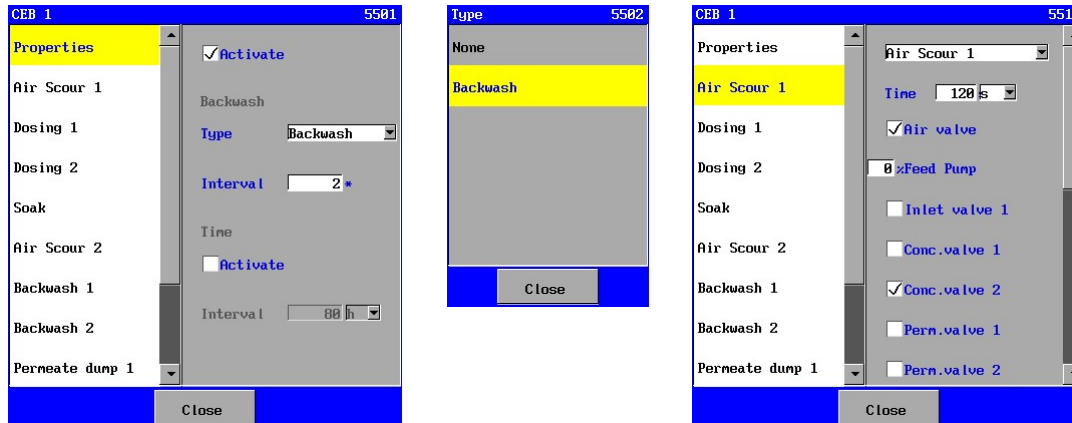

If the phase is activated the various stages can be programmed and you may indicate if the CEB should be started depending on the number of preformed backwashes and/or depending on a interval time (1-9999 minutes/hours).

Should the rinsing be initiated based on the number of executed backwashes, then this can be indicated schematically as follows:



only “Backwash 1” activated.



“Backwash 1” and "Backwash 2” activated.

If a “CEB 2” rinse is started based on the number of “CEB 1” rinses (see § 7.8 “CEB 2” on page 50), it can be represented as follows:



In this case, a “CEB 1” rinse is skipped and replaced by a “CEB 2” rinse.

The name of the sub-process can be set. This is because the order of the sub-processes for this phase is not always identical for every installation.

For each step you can enter which inputs of limits are monitored, which outputs have to be activated and the time duration of the phase (0-9999 seconds / minutes).

If a time of 0 is entered the corresponding phase will be omitted.

In the information window , the remaining number of backwashes and/or remaining interval time will be shown before a CEB will be initiated (see § 10.6 “CEB 1” on page 61)..



7.8. CEB 2

The “CEB 2” phase is used to clean the membrane chemically at adjustable intervals. The backwash may comprise a max. of 11 stages each with a time duration of 0-9999 seconds /minutes.

This phase can be set in the same way as the “CEB 1” phase, with the difference, however, that instead of the interval start based on the number of backwashes, it can be opted for an interval start based on the number of executed “CEB 1” rinses.

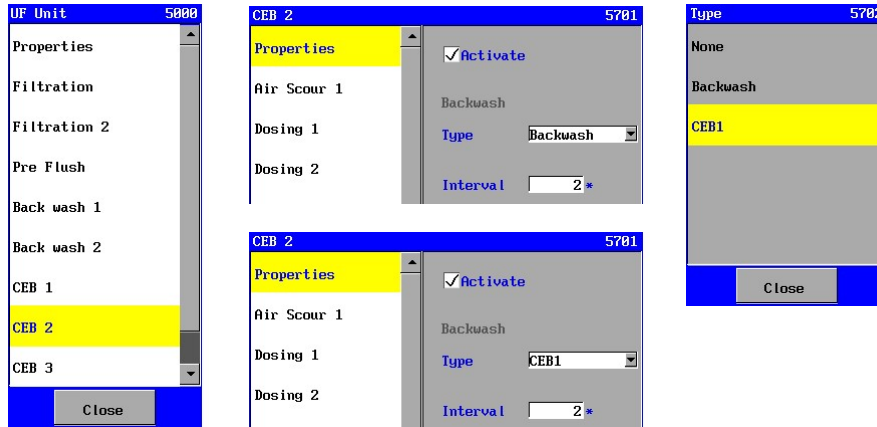

If a “CEB 2” rinse is started, based on the number of “normal” backwashes, then this can be indicated schematically as follows:



If a “CEB 2” rinse is started based on the number of “CEB 1” rinses, it can be represented as follows:



In this case, a “CEB 1” rinse is skipped and replaced by a “CEB 2” rinse.

In the information window , the remaining number of backwashes and/or remaining interval time will be shown before a CEB will be initiated (see § 10.7 “CEB 2” on page 62).

7.9. CEB 3

The “CEB 3” phase is used to clean the membrane chemically at adjustable intervals. The backwash may comprise a max. of 11 stages each with a time duration of 0-9999 seconds /minutes.

This phase can be set in the same way as the “CEB 1” phase.

In the information window , the remaining number of backwashes and/or remaining interval time will be shown before a CEB will be initiated (see § 10.8 “CEB 3” on page 62).

7.10. Integrity test

The “Integrity test” phase can only be switched on and off manually in the “Standby” phase to check the membrane for any leakages.

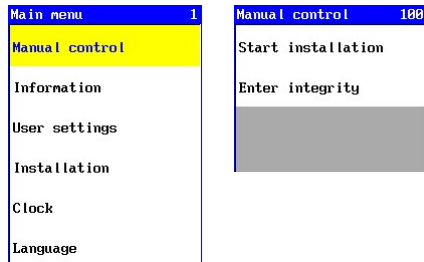

A “rest” stage will first of all be switched on.

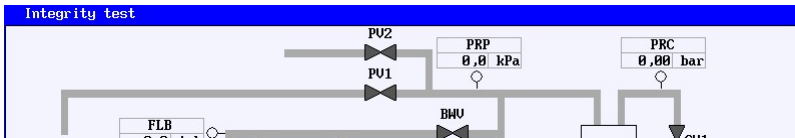

The actual test can subsequently be started and stopped via manual control. (“Start Integrity” / “Stop Integrity”).

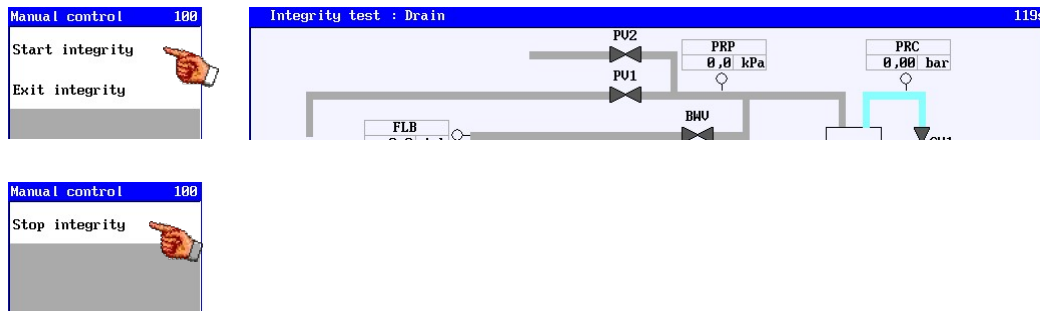

During the test period, a blue line will be shown that indicates the permissible decrease. The measured values will be placed in the graph every second. If the measured value exceeds the permissible limit, this will then be indicated by means of a green line. In the other case, a red line is displayed.

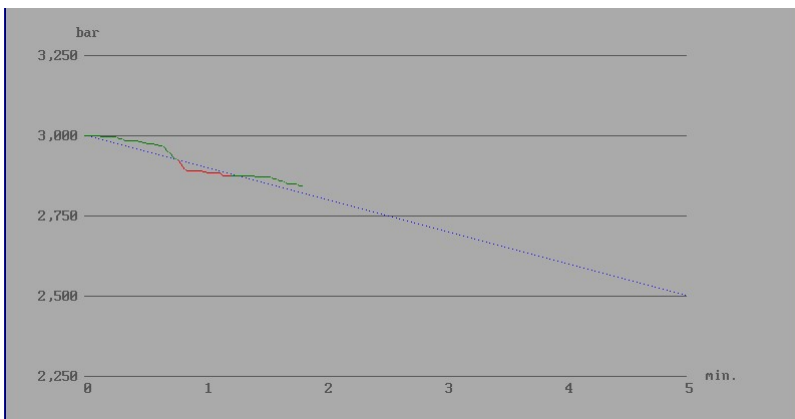

You may quit the “Integrity test” phase manually from the “rest” stage (“Exit Integrity”).



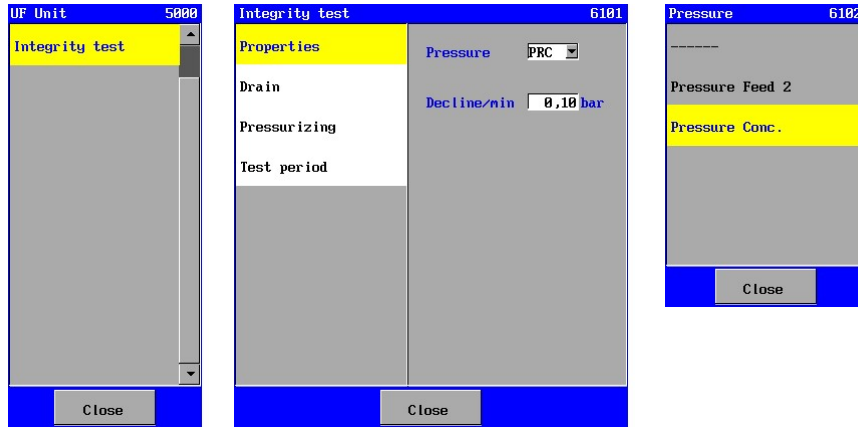

It can be indicated in the "Properties" window which pressure is to be measured during the test. Furthermore, the permissible decrease in the measured pressure (per minute) can be entered. The selected pressure gauge and the decrease will be displayed during the test period.

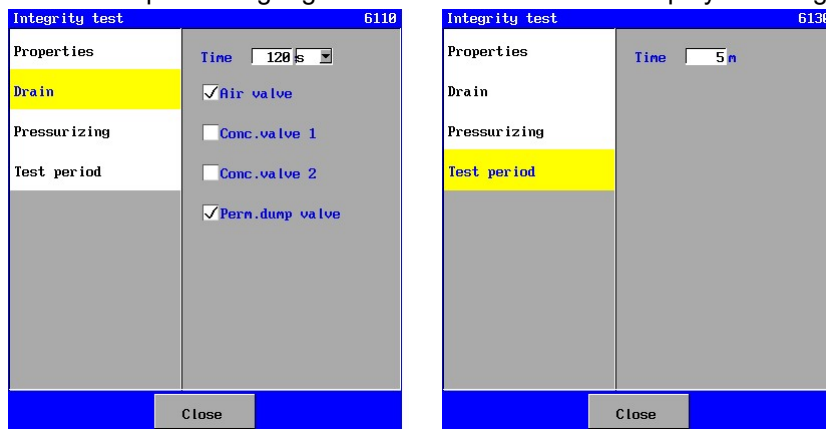

The integrity test may comprise a max. of 3 stages each with a time duration of 0-9999 seconds / minutes.

For each stage you can enter which inputs or limits are monitored, which outputs have to be activated and the time duration of the phase (0-9999 seconds / minutes).

If a time of 0 is entered the corresponding phase will be omitted.

7.11. Standby

No settings can be programmed for the "Standby" phase while all UF process-related functions are switched off, except level switches monitoring and "Filtration Start".. If the unit is not automatically switched on at the level switches or "Filtration Start" the unit may be manually switched off and has to be switched on manually again. (see also § 9 "Manual operation of the unit" on page 57).



If the unit is manually switched off this is shown in the lower bar of the main screen ("Manual Stop").



7.12. Standby Stop

The controller is routinely delivered in the “Standby Stop” phase. The unit will not start up automatically until this is manually switched on (see § 9.1 “Standby stop” on page 57). Once it is switched on, subsequent to a power failure the controller will no longer start up in this phase, unless this is activated via the programming prior to the power failure. (see also § 7.1 “Properties” on page 45).

Even after new software is installed, the “Standby stop” phase will be activated until the unit is switched on manually.

7.13. Alarm

No settings can be programmed for the “Alarm” phase while all UF process-related functions are switched off, except the monitoring on which the UF process is interrupted. The level switches monitoring is also switched off.

Depending on the settings the unit will switch on automatically or it has to be switched on manually.

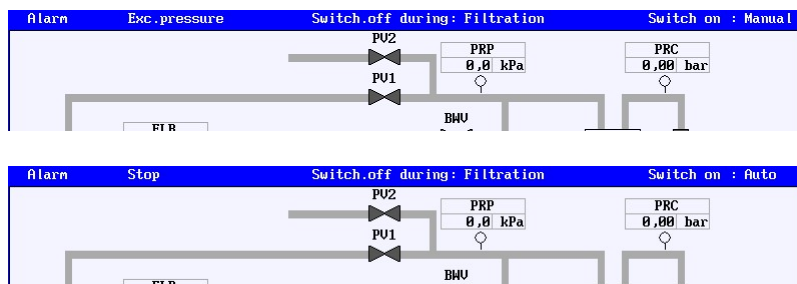

The top bar in the main window shows that the “Alarm” phase is activated. Also shown is the cause of the alarm, the way the unit switched on again and the phase, which is interrupted by the alarm situation.



8. Alarms

The controller features various monitorings of both the operation of the RO unit and the operation of other functions in the controller (such as the SD card function).

8.1. General overview

The alarms can be recorded via an SD card, via e-mail or via an RS232 or RS485 connection. The way the recording operates and can be set is described in § 15.4.1 “Alarm log function” on page 76 and later on in the chapter for the corresponding medium:

SD Card : § 15.4 “Log functions” on page 75.
 E-mail : § 16.2 “Log functions” on page 79.
 RS485 : § 17.2 “Log functions” on page 80.
 RS232 : § 17.2 “Log functions” on page 80.

An alarm output can also be used to provide a warning. A lamp or a buzzer may be activated, for example. § 6.3 “Alarm” on page 22 features a description of the alarm output options and settings.

The “Information” option in the menu can be used to view the last 20 alarms. In this case the date and time are recorded as well as a short description of the alarm, while it is shown whether the alarm situation is active at that time or has been removed. See § 10.9 “Alarm history” on page 62 for more information.

If the UF unit's operation is interrupted by an alarm situation, this will be shown in the main window, which will indicate the cause of the alarm situation, and the phase interrupted by the alarm situation. See § 7.13 “Alarm” on page 53 for more information.

Attention!

In the event of a fault in the configuration file with programming an alarm is invariably given. This cannot be set. In this case the controller has to be reset or a back-up may be uploaded via the boot software, if need be.

8.2. Alarm window

An alarm is given in the alarm window, showing the date and time.

Alarm messages 2			
Power failure	02-11-2009	12:00	Al.
	20-09-2011	11:29	Ok
Exc. pressure	20-09-2011	11:29	Al.
	***	***	Ok

When an alarm output is programmed and activated, this output can be switched off with key “Reset”.

The warning can be deleted from the overview, if the cause of the alarm situation has been removed, by proceeding to the corresponding warning and pressing the key “Reset” again.

The warning remains in the overview when the corresponding monitoring is programmed so that the alarm output automatically switches off when the alarm situation is removed.



An alarm, in the alarm window takes the following form:



The window provides the following information:

- line 1 : x/y x = number of the warning, y = number of warnings
- line 2 : brief description of the alarm situation given.
- line 3 : date and time when the alarm occurs
if "uu-uu-uuuu" and/or "uu:uu" is displayed here, then the clock did not get a valid value at the moment.
- line 4 : date and time when the alarm is removed
If the alarm has not yet been removed this is shown by "***".



For example, it is possible to read off in the window the date and time the controller is switched off (line 3) and when it is switched on again (line 4).

9. Manual operation of the unit



The unit can be controlled manually.

The main menu's "Manual control" features an overview of the manual operations possible at that time.

The options for each phase are shown below.

9.1. Standby stop



During the "Standby Stop" phase the unit is at a standstill and is not activated until the unit is manually switched on. This window can be used to switch on the unit.

9.2. Integrity test

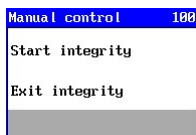

The "Integrity test" phase can be divided into "non-active" status and "active" status.

During "non-active" status the following actions can be applied:

- Start actual integrity (active status) via "Start integrity"
- Quit integrity via "Exit integrity"

You return to the Standby phase.



During "active" status only this status can be stopped ("Stop integrity").

9.3. Standby

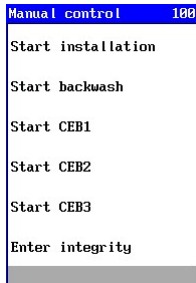

Various actions can be applied during the "Standby" phase.

- Start production via "Start installation"

This option is not displayed if the unrefined water tank is empty, or the filtration stop that depends on the position of the level switches of the storage tank when the storage tank is full, or if the filtration start is dependent on the input "Filtration start" mode and this input is not active.



- Starting the Backwash” phase via “Backwash”
The backwash phase is started. If two backwash phases have been activated, then the backwash phase whose turn it is will be started.
See § 7.6 “Backwash 2” on page 48.
- Starting of CEB 1 via “Start CEB 1”
This option is not displayed if the “CEB 1” phase is not activated.
See § 7.7 “CEB 1” on page 49.
- Starting of CEB 2 via “Start CEB 2”
This option is not displayed if the “CEB 2” phase is not activated.
See § 7.8 “CEB” on page 50.
- Starting of CEB 3 via “Start CEB 3”
This option is not displayed if the “CEB 3” phase is not activated.
See § 7.9 “CEB” on page 50.
- Start Integrity test via “Enter Integrity ”

9.4. Pre Flush



Several actions can be performed during the “Pre-flush” phase (if activated).

- Starting of the filtration via “Start Filtration”
 - Stopping of the installation via “Stop Installation”
- The pre-flush is interrupted and the “Standby” phase is activated. An eventual activated backwash gets ignored in this case.

9.5. Filtration



Various actions can be applied during the “Filtration” and “Filtration 2” phase (if activated).

- Stopping of the filtration via “Stop Installation”
If the filtration starts, depending on the position of the level switches of the storage tank when the storage tank is not full, or if the filtration start is dependent on the “Filtration start” input mode and this input is still active, then a message stating that the installation has been stopped manually (“Manual stop”) appears in the main window.
The installation can then only be switched on again manually.
- Starting the Backwash” phase via “Backwash”
The backwash phase is started. If two backwash phases have been activated, then the backwash phase whose turn it is will be started.
See § 7.6 “Backwash 2” on page 48.
- Starting of CEB 1 via “Start CEB 1”
This option is not displayed if the “CEB 1” phase is not activated.
See § 7.7 “CEB 1” on page 49.
- Starting of CEB 2 via “Start CEB 2”
This option is not displayed if the “CEB 2” phase is not activated.
See § 7.8 “CEB” on page 50.
- Starting of CEB 3 via “Start CEB 3”
This option is not displayed if the “CEB 3” phase is not activated.
See § 7.9 “CEB” on page 50.



9.6. Backwash

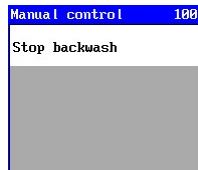

Several actions can be carried out during the “Backwash 1” and “Backwash 2” phases (if enabled).

- Stopping of the backwash via “Stop Backwash”

The backwash is interrupted and the next phase, whose turn it is, is started.

9.7. CEB

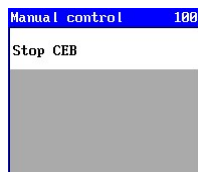

The following actions are carried out during the “CEB 1”, “CEB 2” and “CEB 3” phases:

- Stopping of the relevant CEB via “Stop CEB”

The CEB is interrupted and the next phase, whose turn it is, is started.



10. Retrieve information

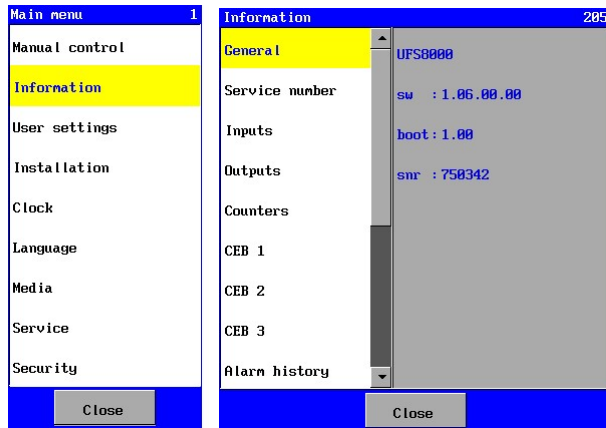

Various types of data can be retrieved from the information menu, such as: the Software version, the service telephone number, the number of service hours, the status of the inputs and outputs, the alarm history, the maintenance interval (if programmed).

The information menu is located in the main menu.

The various information windows are discussed in the following sections.

10.1. General

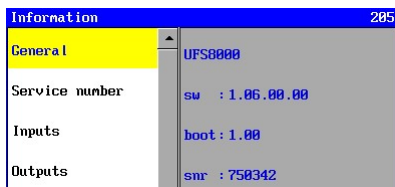

This window shows the Software version and the serial number.

The software is a combined package of various files (including language files) and the application software

- sw: software version of the complete software package
- ap: software version of the application software
- sn: serial number of the controller

The serial number is important for making a back-up on the SD card and for identification during communication (RS232, RS485, Ethernet).

10.2. Service number

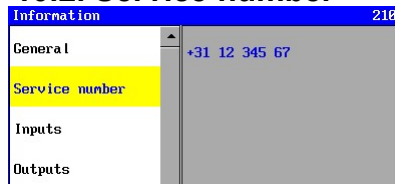

The window provides information about the service telephone number, which is programmable as described in § 23.1 “Service number” on page 95.

10.3. Inputs

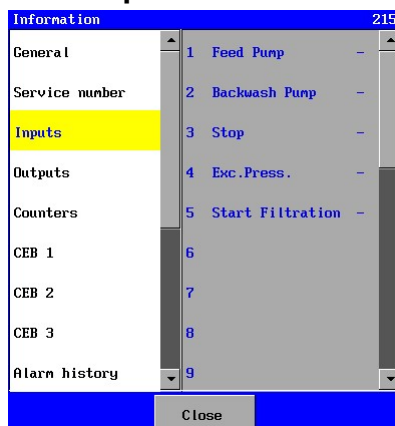

The window shows the status of the inputs.

A line is established as follows:
 <number> <description > <status>

- <number > : indication of input on the print (1="IN 1")
- <description > : brief description of the function
- <status> : input status ("- " input is non-active, "I" input is active)



10.4. Outputs

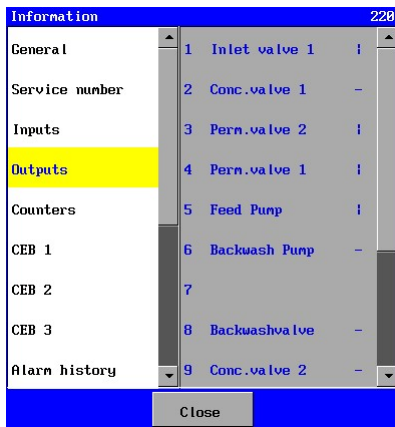

The window shows the status of the relay outputs. A line is established as follows:

<number > <description > <status>

- <number > : indication of relay output on the print (1="OUT 1")
- <description > : brief description of the function
- <status> : output status ("-" relay not activated, "|" relay activated)

10.5. Counters

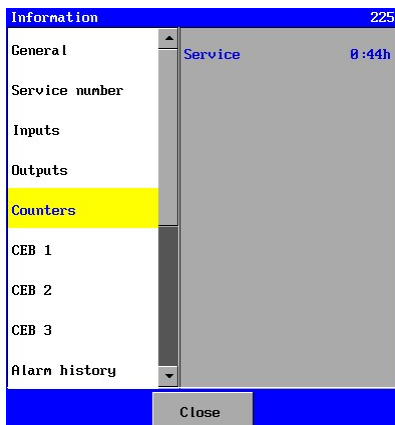

The window provides information about the number of counters.

The counters that will be shown are:

Service

This is a service hour counter showing the total number of production hours.

The number comprises hhh:mm where "hhh" stands for the number of hours and "mm" for the number of minutes.

No further settings are required for this counter.

Maintenance

This counter indicates how long the unit has been in the "production" phase since the last maintenance. If the counter is not activated it will not be visible.

See also § 23.2 "Maintenance" on page 95.

The number comprises hhh:mm where "hhh" stands for the number of hours and "mm" for the number of minutes.

10.6. CEB 1

Information is displayed in the window about the interval counters relating to "CEB 1".

The settings relating to CEB1 can be changed via the "Installation - Programming - UF Unit - CEB1" menu.

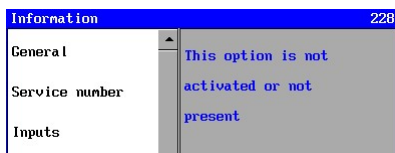

This window is displayed when CEB1 is not activated.

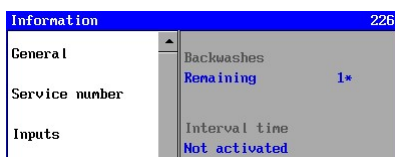

The remaining number of backwashes is displayed here, after which CEB 1 is started. In this case, there is no interval start of CEB1 based on an interval time.

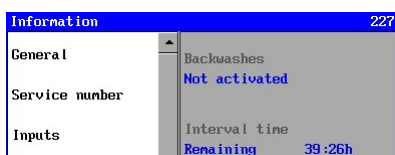

The remaining interval time is displayed here, after which CEB is started. In this case, there is no interval start of CEB1 based on the number of backwashes.



10.7. CEB 2

See § 10.6 “CEB 1” on page 61.

10.8. CEB 3

See § 10.6 “CEB 1” on page 61.

10.9. Alarm history

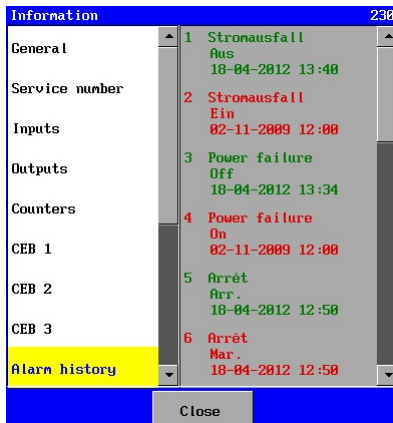

The window gives an overview of the last 20 changes in alarm situations. This means a warning will be provided about the occurrence and the removal of the alarm situation.

A warning is established as follows:

<number ><description >	: number	number of the alarm without any further meaning
	description	brief description of the alarm situation
<status>	: status	indicates whether the alarm that occurred at that time (“On”) or was removed (“Off”).
<date > <time >	: date	date when the change occurred
	time	time when the change occurred

10.10. Ethernet

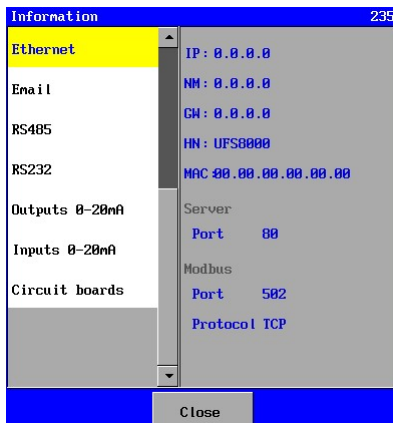

This item shows Ethernet settings that are relevant for internet and e-mail communications (see also § 14 “Ethernet” on page 69).

The windows show the following settings:

IP:	controller IP address.	HN:	Hostname
NM:	Net mask	PO:	Port number
GW:	Default gateway	MAC:	MAC address

Further the settings for the port number and protocol of the Modbus compatible function will be shown.

10.11. E-mail

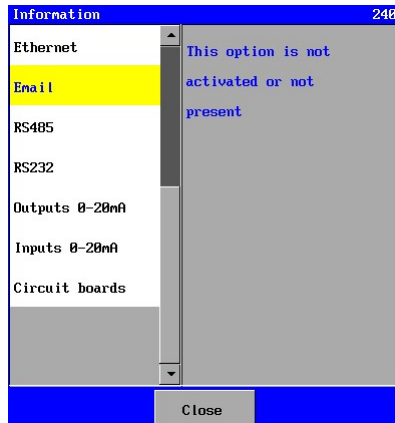

It is possible in the controller to send an e-mail in the event of a specific (alarm) situation or when the situation is removed. An e-mail can be sent switched on or switched off (see § 16.1.1 “Switch on / off e-mail function ” on page 78).

When switched off the following window is shown.

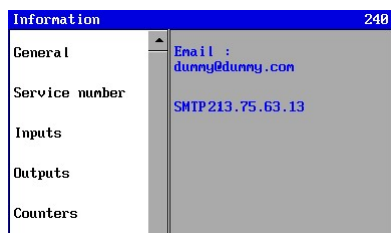

When switched on, the recipient address to which the e-mail warnings will be sent is shown. The SMTP address is also shown.

Further details about e-mail messages are featured in § 16 “E-mail” on page 78.

10.12. RS485

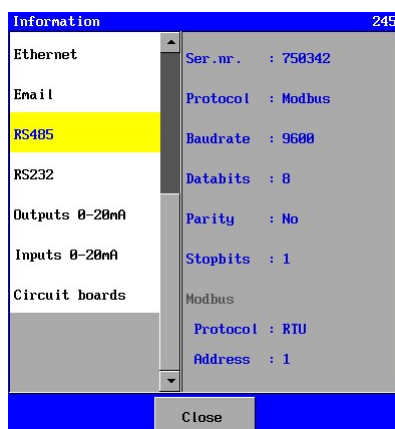

The controller type UFS8x1x-xxx routinely has a RS485 port.

Using this port, information can be sent to a PC, for example, by means of an RS232 / RS485 converter, which is not included in the delivery. The serial number is also displayed as this number is also used for identification for messages about the RS485 line.

The RS485 port-related setting can be programmed in this controller.

When the Modbus compatible function is activated so the programmed protocol and device address in the network will be shown.

10.13. RS232

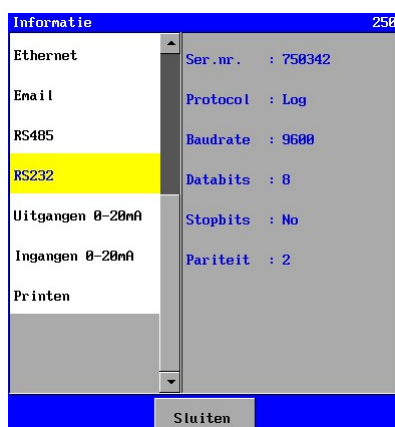

The control type UFS8x1x-xxx has a RS232 port by default. Using this port, information can be sent to a PC, for example. This window displays the settings for the RS232 connection. The serial number is also displayed to identify messages across the RS232 line.

The settings regarding the RS232 port can be programmed freely in this control unit.



10.14. Outputs 0-20mA

Information		255
Ethernet	1 Feed Pump	2,0
Email	2 Backwash Pump	4,0
RS485	3	0,0
RS232	4	0,0
Outputs 0-20mA	5	0,0
Inputs 0-20mA	6	0,0
Circuit boards		
Close		

The currently transmitted current can be read on a recorder in this window. This option is only available if the corresponding optional print ca-3rec is present. If no window function is connected, then no text will be displayed and no current will be transmitted.

10.15. Inputs 0-20mA

Information		257
Ethernet	1 Pressure Feed 1	0,0
Email	2 Temperature	0,0
RS485	3 Pressure Perm.	0,0
RS232	4 Pressure Feed 2	0,0
Outputs 0-20mA	5 Pressure Conc.	0,0
Inputs 0-20mA	6 Flow Feed	0,0
Circuit boards		
	7 Flow Backw.	0,0
	8 Turbidity	0,0
	9	0,0
Close		

This window allows reading the current incoming power supply on a 0-20mA input.

This option is only available when the accompanying optional print ca-fl-pr-3an is present. If there is no function connected to an input, no accompanying text will appear.



10.16. Print composition in the controller

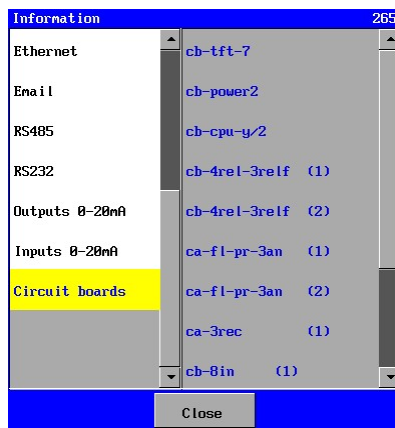

The controller comprises multiple PCBs (Printed circuit board).

The window shows what PCBs the controller consists of. This allows you to check if the PCBs are also actually being detected by the software.

The following PCBs may be displayed:

- cb-tft-7 : front circuit board for LCD display and touch panel
- cb-power2 : power supply circuit board
- cb-cpu-y/1 : cpu circuit board (SD kaart en 8 digitale ingangen)
- cb-cpu-y/2 : cpu circuit board (RS232, RS485, Ethernet, SD kaart and 8 digital inputs)
- cb-4relp-3relf(1): relay circuit board no.1 (4x relay output, 3x relay output)
- cb-8in (1) : basic measuring circuit board no.1 (8 digital inputs))
- ca-fl-pr-3an(1) : optional circuit board with 3 additional inputs (0-20mA)
- ca-fl-pr-3an(2) : 2nd optional circuit board with 3 additional inputs (0-20mA)
- ca-3rec (1) : optional print with 3 outputs (0-20mA)
- cb-4relp-3relf(2): relay circuit board no.2 (4x relay output, 3x relay output)
- cb-8in (2) : basic measuring circuit board no.2 (8 digital inputs))
- ca-fl-pr-3an(3) : optional circuit board on 2nd basic measuring board with with 3 additional inputs (0-20mA)
- ca-fl-pr-3an(4) : 2nd optional circuit board on 2nd basic measuring board with with 3 additional inputs (0-20mA)
- ca-3rec (2) : optional circuit board on 2nd basic measuring board with with 3 additional outputs (0-20mA)



11. User settings

11.1. LCD Display

The control unit has lighting in the LCD Display.



In this window you can specify the brightness of the lightning.

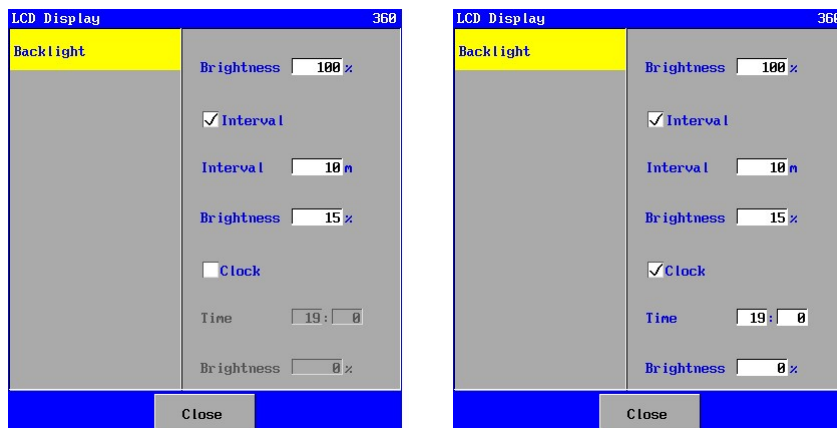

Furthermore you can specify in this window whether the lighting should be dimmed or switched off (=0%) when the touch panel is not used for longer than a certain period of time.

Also you can specify whether the whether the lighting should be dimmed or switched off (=0%) after a programmed time.

When the touch panel is used after this time, the lightning will be switched on for the selected interval time (when interval time activated). After this time, the dim level as programmed for the interval time will be activated.



12. Clock

12.1. General

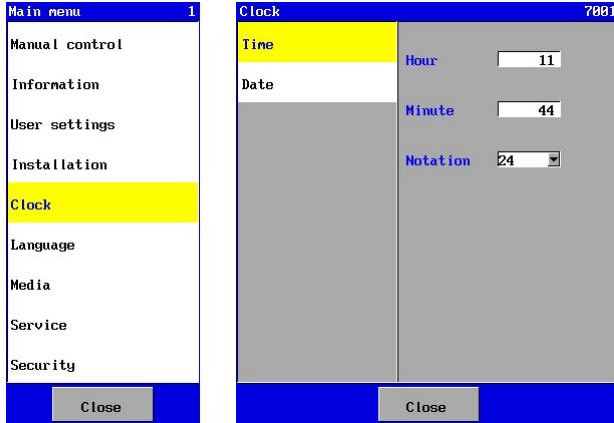

The time and date can be set in the controller.

The time and date are used in various functions, such as data “logging”.

The clock setting option is located in the main menu.

The controller has a battery so the time and date can be kept. If the controller is switched on again the time and date have to be reset. In the case of summer time and winter time, the time and date have to be adjusted manually.

12.2. Time setting

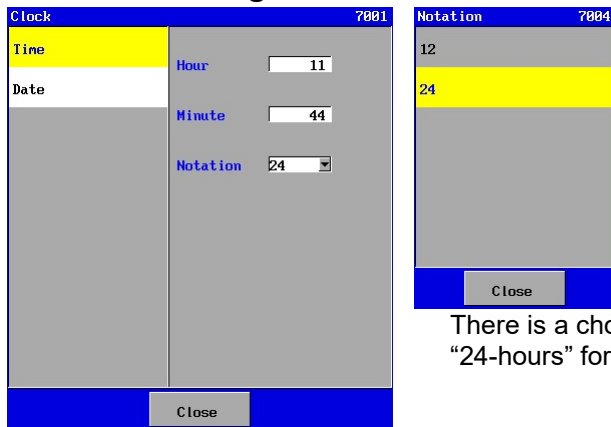

The time setting window can be used to change the hours, minutes and time format. The general operation for entering a value (see § 4.3.1 “Set value or text” on page 9) is used to change the hours and minutes.

The general operation for making a choice from a list (see § 4.3.3 “Set dropdown list” on page 9) is used to change the time format.

There is a choice between a “12-hours” (“03:34 AM”) and a “24-hours” format (“16: 54”).

The changed time is directly up-to-date.

The time format will also apply directly. However, this is not stored when you quit the main menu.

12.3. Date setting

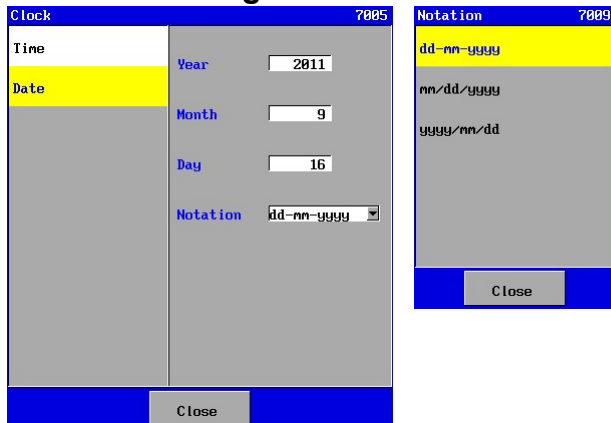

The date setting window can be used to change the years, months, days and the date format.

The general operation for entering a value (see § 4.3.1 “Set value or text” on page 9) is used to change the years, months and days.

The general operation for making a choice from a list (see § 4.3.3 “Set dropdown list” on page 9) is used to change the date format.

There are three formats to choose from.

The changed date is directly up-to-date. The data format will also apply directly. However, this is not stored when you quit the main menu.

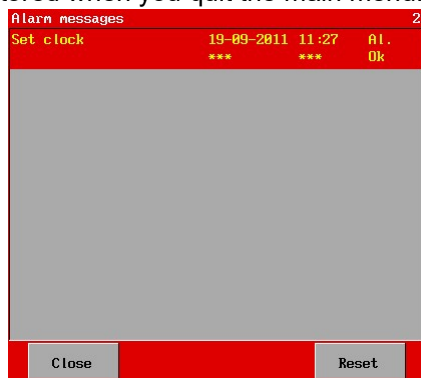

The control unit also checks whether the date is correct (year > 2009). If this is not the case, then a message will be displayed in the alarm window that the clock must be set.

13. Language setting

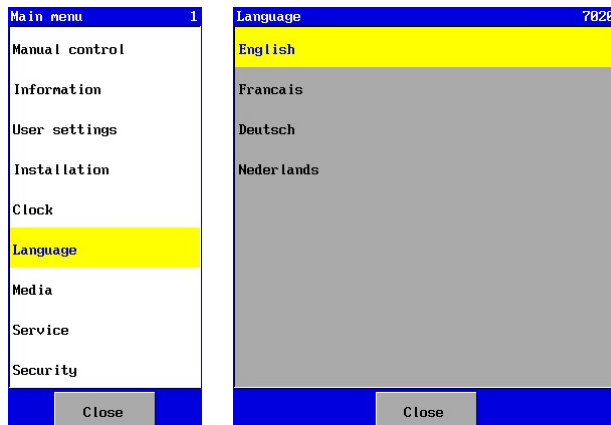

The controller offers you the opportunity to choose from different languages.

The language setting option is located in the main menu.

13.1. Change language setting

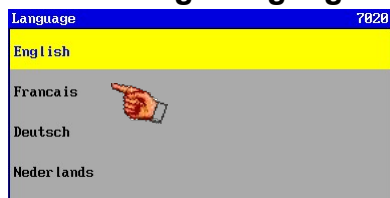

Select the required language.



You will then be asked to confirm your choice.

The texts in the menu are immediately changed in the changed language. The language setting is not, however, stored after you quit the main menu.



14. Ethernet

Attention ! This chapter only applies to control unit type UFS8x1x-xxxx.

The controller is suitable for communicating via Ethernet. The web server on the controller allows information to be exchanged with the controller via a web browser (such as Internet Explorer) (see also § 22 “Internet” on page 91).

In order to adapt the controller the Ethernet connection has to be set correctly.

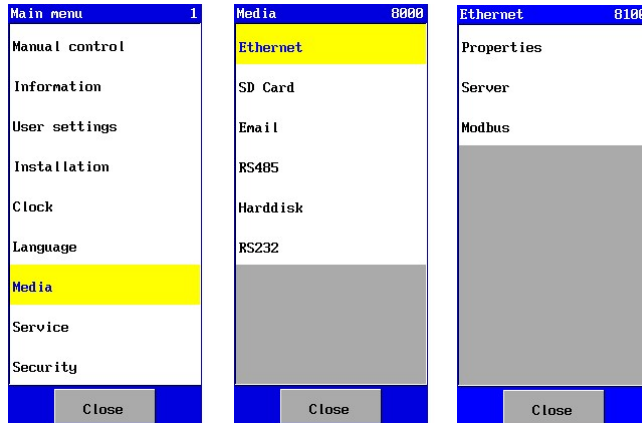

This chapter will explain how the Ethernet connection can be set.

The Ethernet menu is located in the main menu.

14.1. Configuration

14.1.1. DHCP function

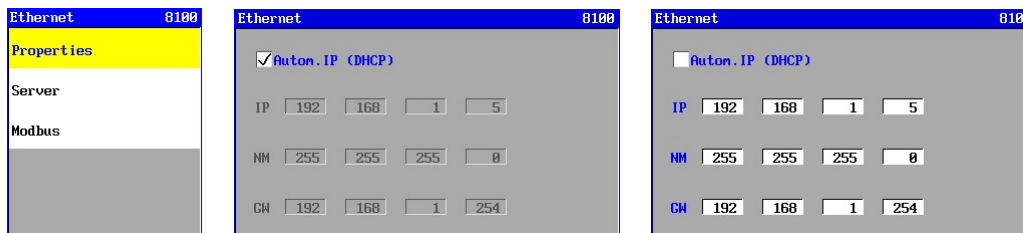

The controller has a “DHCP” function. This function is enabled when option “Autom.IP (DHCP)” has been activated. When the controller starts up, a check is made for roughly 5 seconds to see if a DHCP server is available on the network and if an IP address is automatically assigned. If there is no DHCP server the set IP address is used (see § 14.1.2 “IP address” on page 69). In that case the “Autom.IP (DHCP)” option should be turned off.

If the IP address is automatically assigned via an DHCP server, the IP address is read off via the information menu (see § 10.10 “Ethernet” on page 62).

14.1.2. IP address

The IP address is the controller's address within the network to which the controller is connected. The first 3 numbers are normally the same for all connected components on the network. The final number has to be unique within the network.

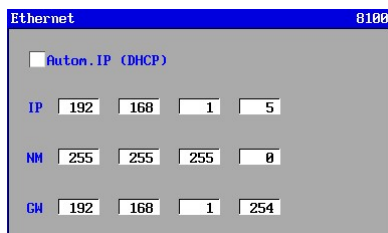

In the window the IP address is entered after “IP”.

The controller also has a DHCP function (see § 14.1.1 “DHCP function” on page 69) to check if the controller is automatically assigned an IP address from a DHCP-server (in a router, for example).

If this is the case, the IP address set here is not used. The automatically assigned number can be read off in the information menu (see § 10.10 “Ethernet” on page 62).



14.1.3. Subnetmask

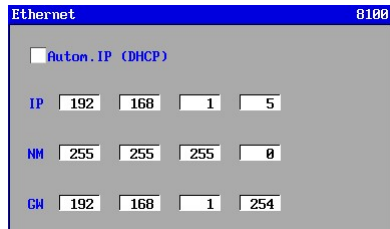

In the window the subnetmasker is entered after “NM”.

This generally has to be set as 255.255.255.0, showing that the first 3 numbers of an IP address, within the network, have to be the same and the final number has to be unique.

14.1.4. Default gate-way

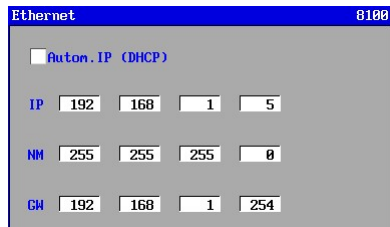

In the window the address of the standard gateway is entered after "GW".

The address has to be set in the IP address of the appliance (router or modem, for example) connecting the network with another network (such as the internet).

14.1.5. HTTP port number

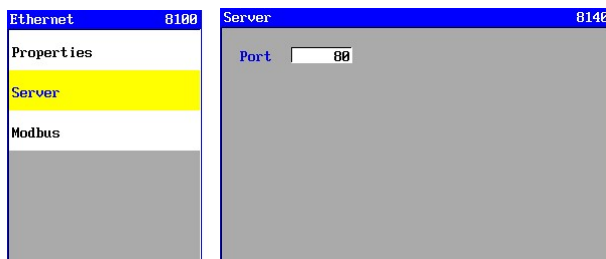

The port number 80 is routinely used for the internet (World Wide Web). The port numbers 1 to 1023 are officially reserved but may be set, if necessary.

The port number may have to be changed if, for example, 2 controllers are placed behind a modem or router that both have to be accessible via the internet. In the router or modem another port has to be earmarked for both controllers. A corresponding port number then has to be entered in the window.

If a port number other than port 80 is used then a colon and port number have to be entered in the browser's URL bar, after the IP address or domain name. For example: 198.162.0.10:1024 for the use of port number 1024.

Attention!

The changed port number becomes active only if the controller is switched off and switched on.

14.1.1. Modbus

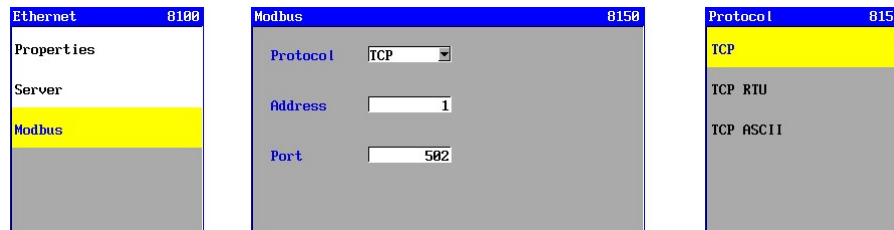

On the Ethernet port there is a Modbus compatible function available. Here you can set the Modbus protocol, port number and device address for the Modbus function in the network. See § 21 “Modbus” at page 88 for more information.

14.2. Access via internet (WAN)

Here it is indicated how the modem can be set to be granted access to the controls via the internet (WAN). It further describes how the IP address of the modem can be traced on the internet.

The modem is connected to two networks, namely the internet (WAN = Wide Area Network) and the local network (LAN = Local Area Network). The modem has an IP address in both networks. To gain access via the internet to the control, a so-called "NAPT entry" (Network Address Translation) must be created in the modem.

Thus the modem will know to which IP address in the local network the incoming messages are to be transmitted.

If the DHCP (DHCP = Dynamic Host Configuration Protocol) server is activated in the modem, the IP address of the controller (which is accessible via the internet) must be reserved ("DHCP lease"). The controls are then always assigned the same IP address. This is necessary because only a fixed IP address can be specified in the "NAPT entry" to control the internet access.

Below is a schematic example of a configuration. Here the "PC-1" and "modem-1", for example, are placed in the office of the supplier of the installation.

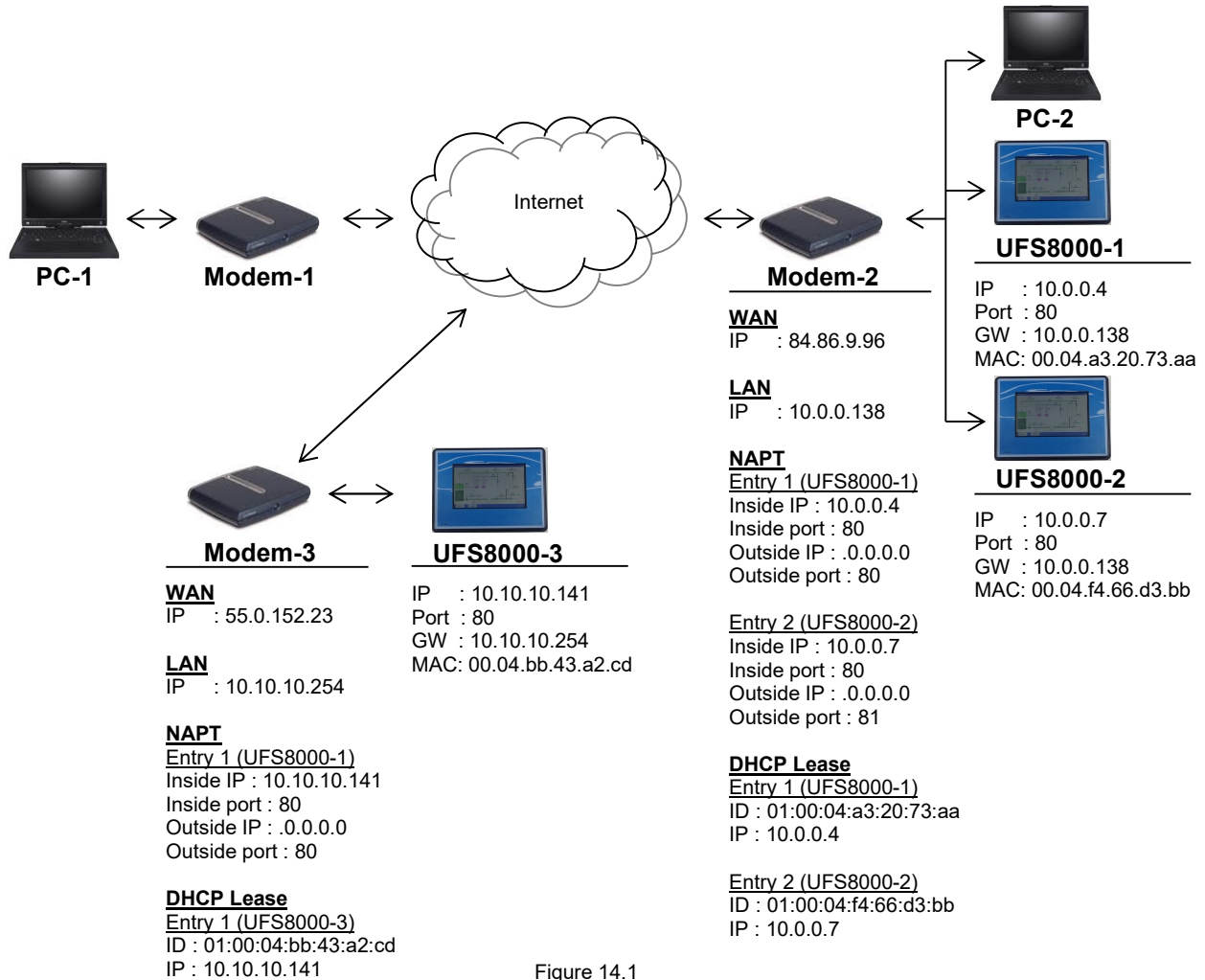

Figure 14.1

Examples:

1) If you want to connect from your PC (PC-1) with control UFS8000-1 then you must enter the following in the URL bar of the internet browser:



2) If you want to connect from your PC (PC-1) with control UFS8000-2 then you must enter the following in the URL bar of the internet browser:

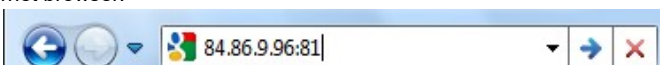

3) If you want to connect from your PC (PC-1) with control UFS8000-3 then you must enter the following in the URL bar of the internet browser:

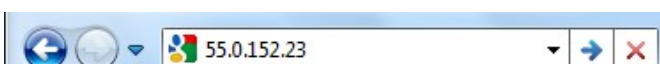

14.2.1. IP address of the modem (WAN)

The IP address of the particular modem on the internet can be obtained by inserting <http://www.whatismyip.com> in the URL bar of the browser on a computer that is connected to the local network “behind” the particular modem. A web page will appear with the IP address of the modem. This address must be used to access the control via the internet. If this is done on, for example, PC-2 (see Figure 14.1), then the IP address “84.86.9.96” will be displayed. This IP address is not adjustable.

14.2.2. IP address of the modem (LAN)

The modem is equipped with a specific IP address in the local network. This IP address can eventually be modified, but this is not really common. This IP address can be found in the instruction manual of the modem. The modem can subsequently be connected to a PC.

The IP address of the PC should be set so that it can communicate with the modem. To connect to the modem, the IP address of the modem must be entered in the URL bar of the browser (for example, Internet Explorer).

14.2.3. NAPT

A “NAPT Entry” (“Network address port translation”) is to be set in the modem. This will give access to the control of the internet. The IP and port number of the control are specified in the “NAPT entry”. See § 14.2.2 “IP address of the modem (LAN)” on page 72, how to make a connection between a PC and the modem.

If you have two controls in the local network that should be accessible via the internet, they must communicate via the internet through different ports. Standard communication is via port 80. The modem will transmit the incoming messages (from the internet) directly to the control with a specific IP address and port number in the local network.

Example with a Speedtouch 520i modem:

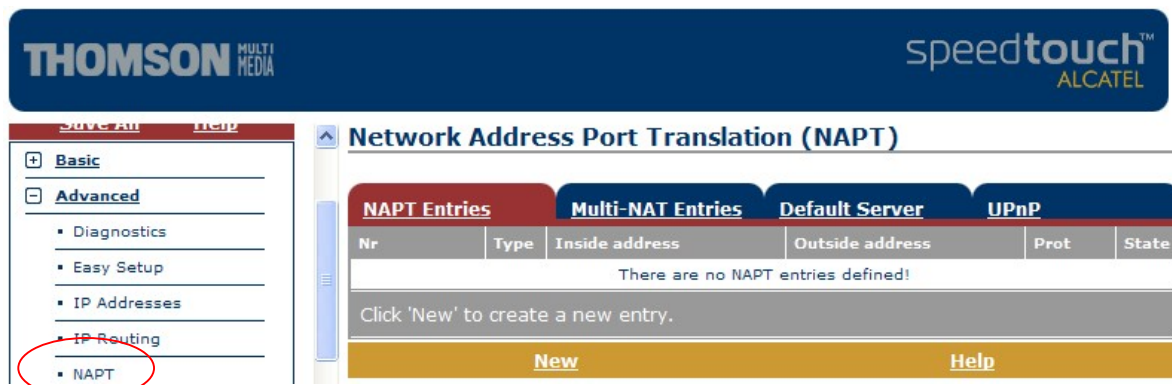

Open “Advanced” in the menu and click subsequently on “NAPT”. Make a “NAPT Entry” by clicking on “New”.

NAPT Entries		Multi-NAT Entries		Default Server		UPnP	
Nr	Type	Inside address	Outside address	Prot	State		
-	-	-	-	-	-		
Specify following properties and click 'Apply' to commit.							
NAPT properties:							
Protocol:	tcp						
Inside IP:	10.0.0.4		Inside Port:	80			
Outside IP:	0.0.0.0		Outside Port:	80			
Apply		Clear			Help		

Enter the IP address (in this example: 10.0.0.4) and port number (in this example: 80) of the control that should be accessible via the internet.

If several controls should be accessible via the internet, then one should make use of the ports. The setting “Outside Port” should be set differently for each control. This port number should then be used in the URL bar of the browser of the PC (also see the examples given in Figure 14.1).

Save the settings by clicking on "Save All".

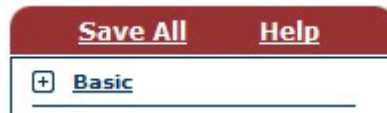

14.2.4. DHCP Lease

If the DHCP server in the modem is activated (see also § 14.1.1 "DHCP function" on page 69), a so-called "DHCP Lease" must be created. This establishes that the modem always assigns a fixed IP address to a particular device (in this case the control) in the local network. The IP address should be equal to the IP address (Inside IP) that is set in the "NAPT entry". See § 14.2.2 "IP address of the modem (LAN)" on page 72, how to connect a PC to the modem.

Example with a Speedtouch 520i modem:



Open "Advanced" in the menu and then click on DHCP. It is subsequently indicated in the "Server Config" window whether the DHCP server is enabled. If so, then the following steps must be performed.

Click on "Server Leases" and an overview of the set "Leases" will be displayed. Click on "New" to create a new "Lease".

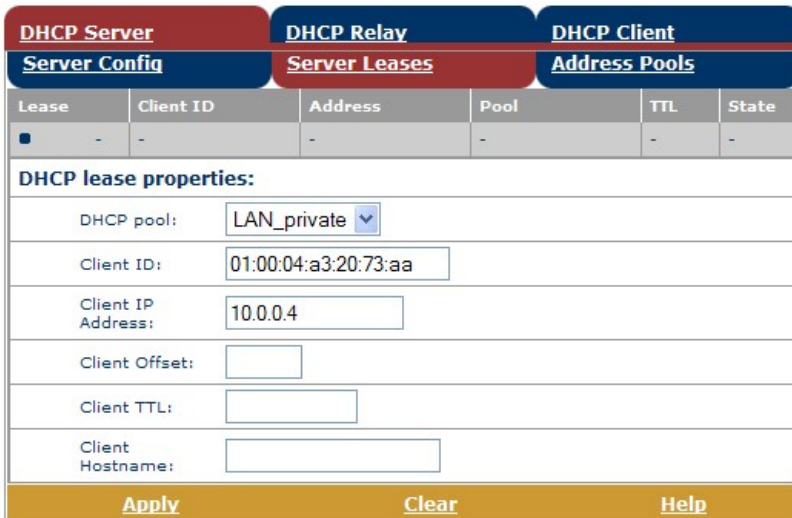

Enter "01" in "Client ID" then and thereafter the MAC address (see § 10.7 "Ethernet" on page 35) of the control and enter the IP address of the control in the "Client IP Address". Then on "Apply".

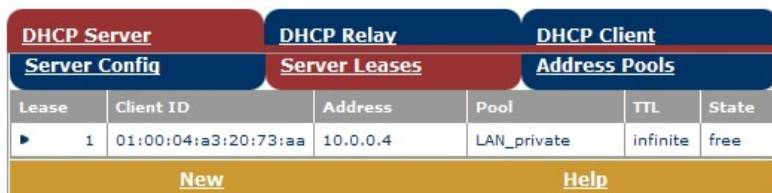

The adjacent represented overview will now be displayed.

Save the settings by clicking on "Save All".





15. SD card

The SD card function can be used for various purposes such as changing application software, making “OEM” software, storing alarms, measurement data and process data.

This chapter will explain how this can be set and how the cards are organised in relation to the directory structure.

For the specifications of the SD cards see § 37 “Technical specifications” on page 117.

15.1. Arrangement of the cards

A separate card has to be created for each SD card application.

The following types of cards may be distinguished:

- cards with original software
- cards with “OEM” software
- cards with software back-ups and log files

One card type may display data about different types of controllers.

For example, one card with original software may feature the original software of both type RGS8000 and type UFS8000 controllers, etc....

The distinction is made to keep the cards of the installer (OEM) and end user separate. A SD card can also be kept in which only original software is placed.

15.2. Directories

Below is a description of where the files are stored on a SD card.

The files are invariably stored in pre-defined directories.

The directory structure is as follows:

Original software	: X:\ <controller type > \ software \ original \ Vxxxxxx_xx
OEM software	: X:\ <controller type > \ software \ oem \ Vxxxxxx_xx
Back-up software	: X:\ <controller type > \ software \ back-up \ Vxxxxxx_xx_jjmdd
Alarm log files	: X:\ <controller type > \ log \ <sssss> \ alarm
Data log files	: X:\ <controller type > \ log \ <sssss> \ data
Process log files	: X:\ <controller type > \ log \ <sssss> \ process

Explanation:

X:\	= Main directory of the SD card
Vxxxxxx_xx	= Software version number
Vxxxxxx_xx_jjmdd	= Software version number with date of the back-up
<controller type >	= for example RGS8000, UFS8000, etc...
<sssss>	= The controller's serial number. Each serial number consists of 6 digits

Attention!

Any departure from this directory structure could result in the software failing to identify the card so the card's data cannot be read.



15.3. Software files

The controller is routinely delivered with the latest Software version (at that time).

If further changes are subsequently made in the software the software may be adapted by copying the original software to a SD card and loading via the Boot program in the controller (see § 27 “Boot software” on page 104). Get in touch with your supplier to obtain the latest version.

Once the original software is loaded, the controller will be reset to the factory settings. You need to reset the controller with the settings you require.

After the settings have been changed, these settings may be stored together with the software as a back-up. The back-up may be used, for example, to secure the settings of a, normally, properly functioning unit, prior to making settings or software-related changes.

To make a back-up see § 19.2 “Back-up by the end user ” on page 83.

If the back-up made has to be replaced you may use the boot program again (see § 27 “Boot software” on page 104).

15.4. Log functions

There are three types of log functions: alarm logging, data logging (status / measurements) and process information logging. As for how these can be set, first of all the SD card function has to be switched on to access the log functions. See the windows below.

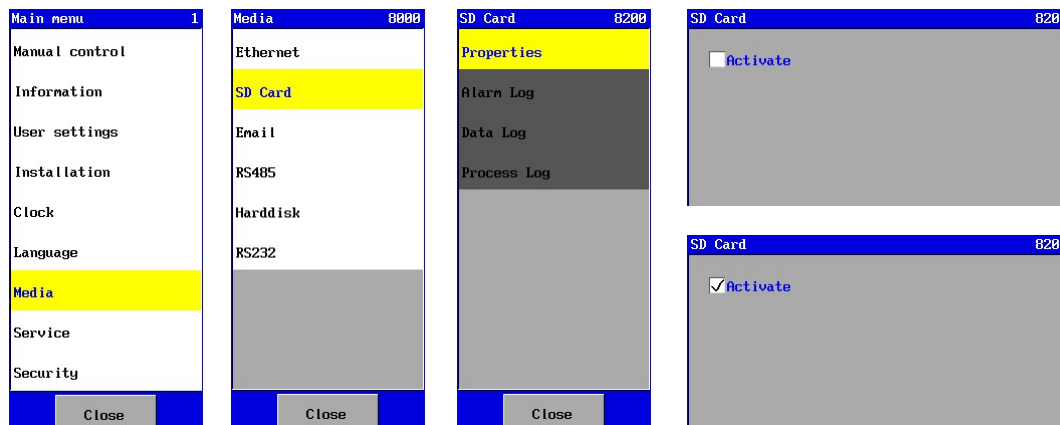

Attention!

The SD card function has to be switched off before the SD card can be removed from the controller.

This is to prevent the files from becoming unreadable. Files in XML format are therefore correctly closed.



15.4.1. Alarm log function

If an (alarm) warning has occurred in the system, the warning may be stored in the SD card. The “Alarm Log” option then has to be chosen in the “Log” menu.

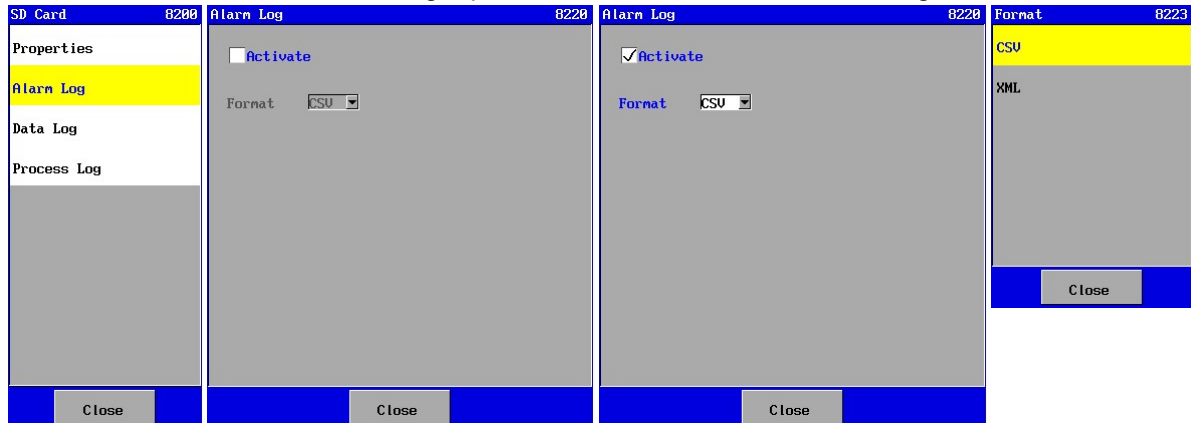

The alarm log function can be activated via this window and the “format ” of the information sent can be specified. The information can be stored in CSV format and in XML format .

The size of the file may vary somewhat. About 100 bytes can be counted for each alarm.

For more information about the log function, see § 20.1 “Alarm ” on page 84.

15.4.2. Data log function

In order to check the quality of the water at a later time, for example, the measurement value can be logged.

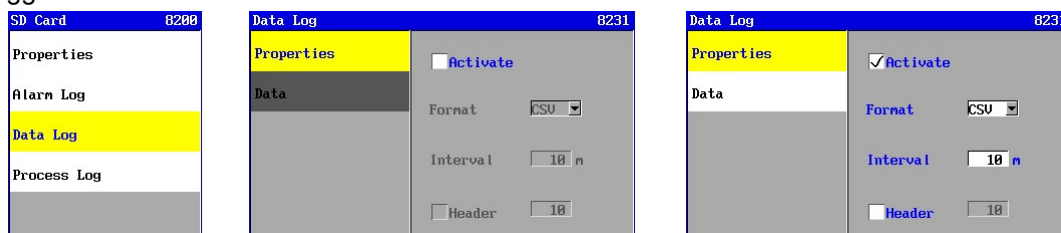

Towards this end, the data log function has to be activated (in “Properties” option).

CSV: For all data logging roughly 100 kB a day.

XML: For all data logging roughly 200 kB a day.

Properties

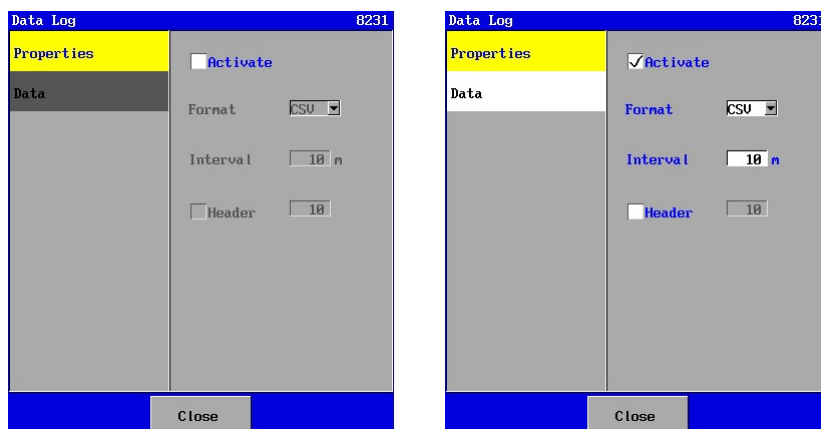

The “Properties” option is used to activate the data log function and to specify the “format” of the stored information. The information can be stored in CSV format and in XML format .

An interval time of between 1 and 9999 minutes may be specified for logging.

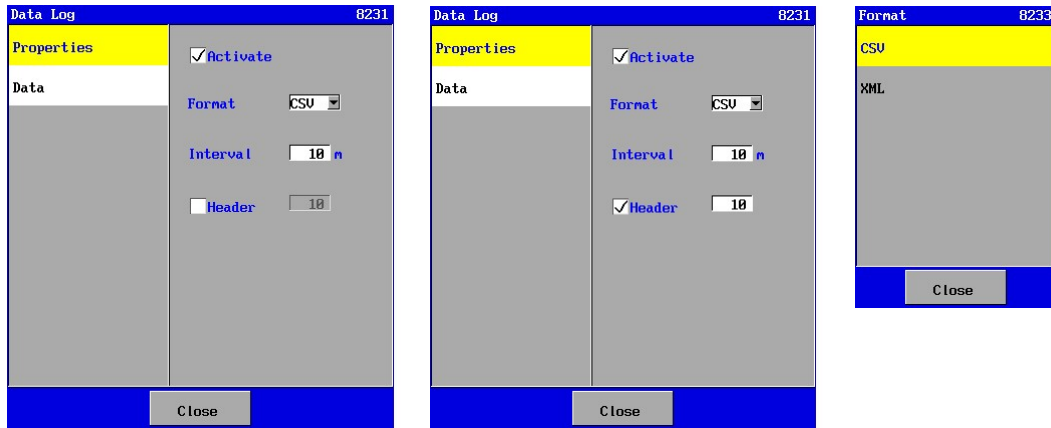

The “Header” field (appears only if the CSV format is set) can be used to indicate if an information line has to be added after a specific number of lines with status / measurement information (in the above example after 10 lines). An interval of between 1 and 999 lines may be specified. The data is separated by a comma. For more details about the log functions and the format type see § 20.2 “Data information” on page 85.

Data



The “Data” option is for setting which data is logged.

For this the field of the corresponding function has to be “checked”. The status of the measurement value of the corresponding function will then be featured in the information line.

15.4.3. Process log function

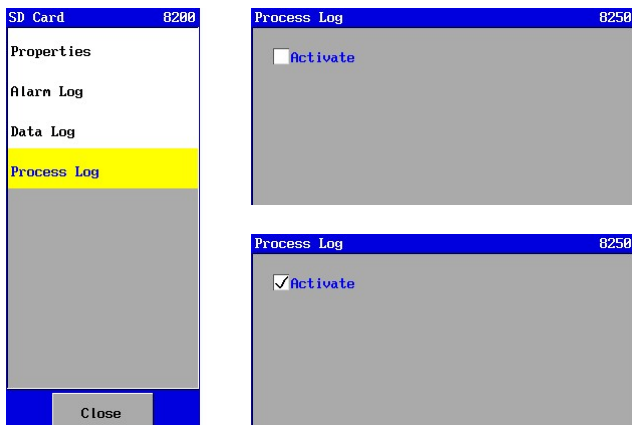

This window can be used to activate the process log function. The data is stored in ASCII format and cannot be set. The format appears as follows:
date time unit (sub) process

If the controller has been voltage free this is also indicated in the file, with the date and time the controller was switched on and off.
The size of the file may vary somewhat. Roughly 50 bytes can be counted on for each process change or power failure.
For more information about the log function see § 20.3 “Process data” on page 87.



16. E-mail

Attention ! This chapter only applies to control unit type UFS8x1x-xxxx.

Attention ! A server without authentication (and without SSL) should be used.

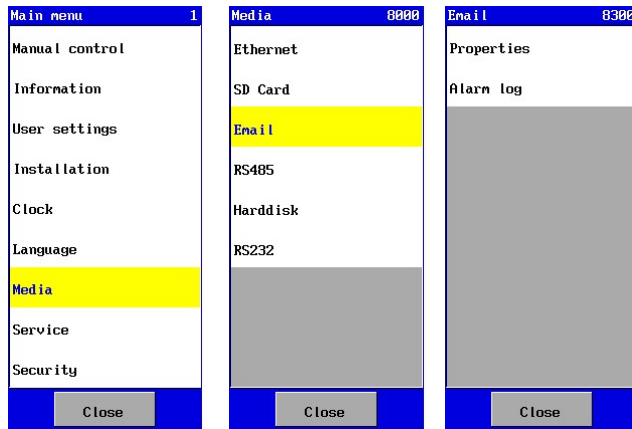

The controller can be used to send e-mails with (alarm) warning. The options will be explained in this chapter as well as how the controller has to be set.

The e-mail menu is located in the main menu.

The configuration can be set via the "Properties" option. The situation in which an e-mail is sent can be set via the "Log" option.

16.1. Configuration

To send e-mails a number of parameters have to be set in the controller.

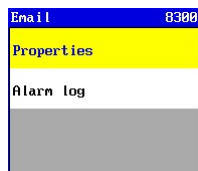

In this window the following items have to be set:

- Switch on / off e-mail function
- E-mail address of the recipient
- IP address of SMTP-server

16.1.1. Switch on / off e-mail function

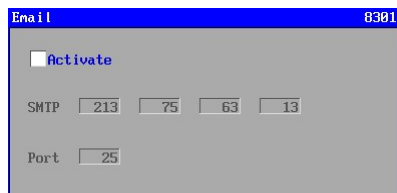

The e-mail function can be switched on and off in the window via the "Activate" option.

If the option is "checked" the function is switched on and the various programmable settings are accessible.

16.1.2. IP address of SMTP server

To send an e-mail the IP address of an internet provider's SMTP-server is required for the local internet connection. This should be a server without authentication (and without SSL).

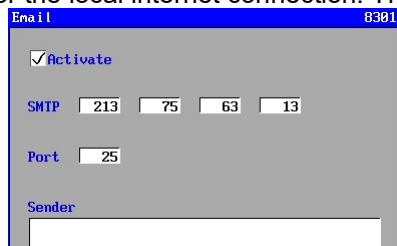

Generally speaking, only the domain name of the SMTP-server is known. This can be found in your "e-mail account", for example (such as "Outlook"), the address specified in the SMTP-server.

<http://www.whatsmyip.org/whois/>, for example, allows you to search for the related IP address of the

SMTP server by entering the domain name.

16.1.3. E-mail sender

The controller will send an e-mail with a programmable sender name

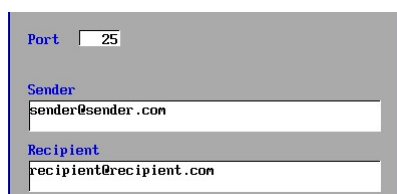

An e-mail address with up to 55 characters may be entered.



16.1.4. E-mail address of the recipient

There is an option to enter the e-mail address of the recipient (where the controller has to send the-mails).

An e-mail address with up to 55 characters may be entered.

16.2. Log functions

If an (alarm) warning has occurred in the system a warning can be given via e-mail. The “Log” option then has to be chosen in the “Email” menu.

16.2.1. Alarm log function

If an (alarm) warning has occurred in the system a warning can be given via e-mail. The “Alarm Log” option then has to be chosen in the “Log” menu.

If the alarm log function is activated (in “Properties”) option the “Alarms” option will be automatically displayed.

Properties

The “Properties” option allows the alarm log function to be activated and the “format” of the information sent to be specified (only the CSV format is available at the present time).

The message in the e-mail is established as follows:

- date, time, status of the warning (on/off),description of the warning,
- phase where the warning occurred (where relevant).

For more information about the log function see § 20.1.1 “CSV format” on page 84.

Warnings

The “Alarms” option can be used to set which (alarm) warnings will require an e-mail to be sent.

For this, the field for the corresponding warning has to be “checked”.

An e-mail will then be sent at the time the situation occurs and when the situation is removed.

17. RS485

Attention ! This chapter only applies to control unit type UFS8x1x-xxxx.



The controller has an RS485 connection.

The RS485 connection can be used for data logging (status / measurement), alarms and process data. This chapter will explain how this can be set.

The RS485 menu is located in the main menu.

17.1. Configuration

17.1.1. Configuration in the controller

The configuration of the RS485 connection is programmed. The default connection is configured as follows:

- Baudrate 9600 Baud
- Data bits 8
- Parity No
- Stop bits 1

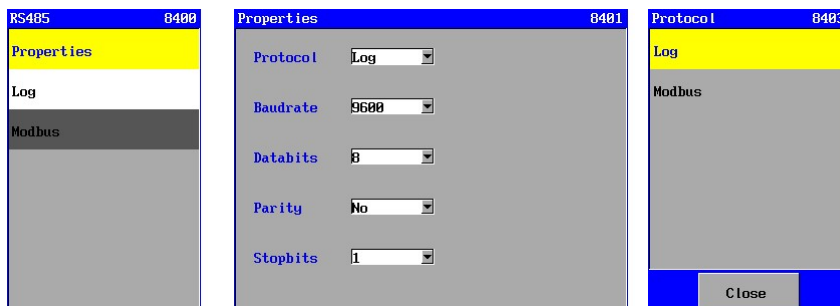

Also you can set the protocol that should be activated on the serial line. There is a choice between the log functions and the Modbus compatible function.

17.1.2. Configuration of the “Hyperterminal”

The controller can be connected with a PC by means of an RS232 / RS485 converter, which is not included in the delivery. For example, a “Hyperterminal” can be used to consult and possibly store the data sent by the controller. “Hyperterminal” is routinely available in “Windows” under “Desktop accessories – Communications”.

17.2. Log functions

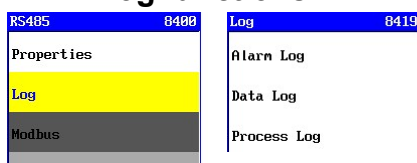

There are three types of log functions: alarm logging, data logging (status / measurements) and process information logging. Below is an explanation of how these can be set.



17.2.1. Alarm log function



If an (alarm) warning has occurred in the system a warning may be given via the RS485 connection on a PC, by means of an RS232 / RS485 converter, which is not included in the delivery.

The "Alarm Log" option then has to be chosen in the "Log" menu. The alarm log function is activated in this window and the "format" of the information sent can be specified (only the CSV format is possible at the present time).

date, time, status of warning (on/off), description of the warning, phase where the warning occurred (where relevant).

For more information about the log function see § 20.1.1 "CSV format" on page 84.

17.2.2. Data log function

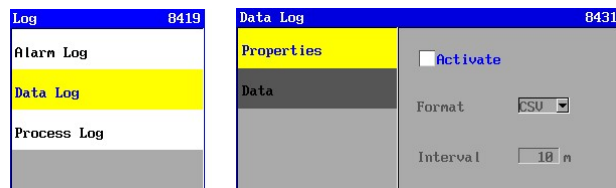

In order to check the quality of the water at a later time, for example, the measurement value can be logged.

Towards this end, the data log function has to be activated (in "Properties" option).

Properties

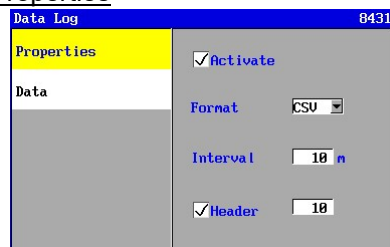

The "Properties" option is used to activate the data log function and specify the "format" of the information sent (only the CSV format is possible at the present time).

An interval time of between 1 and 9999 minutes may be specified for logging.

The "Header" field (appears only if the CSV format is set) can be used to indicate if an information line has to be added after a specific number of lines with status / measurement information (in the above example after 10 lines). An interval of between 1 and 999 lines may be specified. The data is separated by a comma.

For more details about the log functions and the format type see § 20.2.1 "CSV format" on page 86.

Data

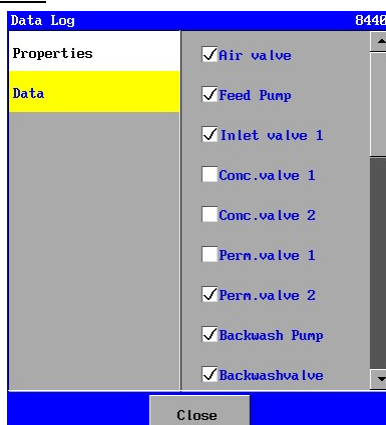

The "Data" option is for setting which data is logged.

For this the field of the corresponding function has to be "checked". The status of the measurement value of the corresponding function will then be featured in the information line.



17.2.3. Process log function

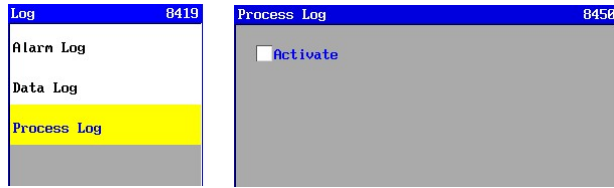

This window can be used to activate the process log function.

The data is sent in ASCII format and cannot be set. The format appears as follows:
date time unit (sub) process

If the controller has been voltage free this is also indicated in the file, with the date and time the controller was switched on and off.

For more information about the log function see § 20.3 “Process data” on page 87.

17.1. Modbus

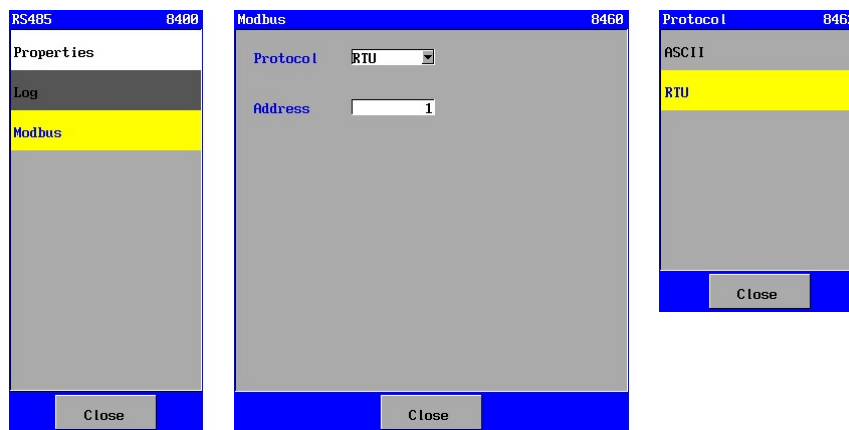

On the RS485 line you have the possibility to activate a Modbus compatible function (see “Properties”). The protocol and the device address in the network can be set. See § 21 “Modbus” at page 88 for more information.

18. RS232

Attentie ! Dit hoofdstuk is alleen van toepassing voor de besturing type UFS8x1x.

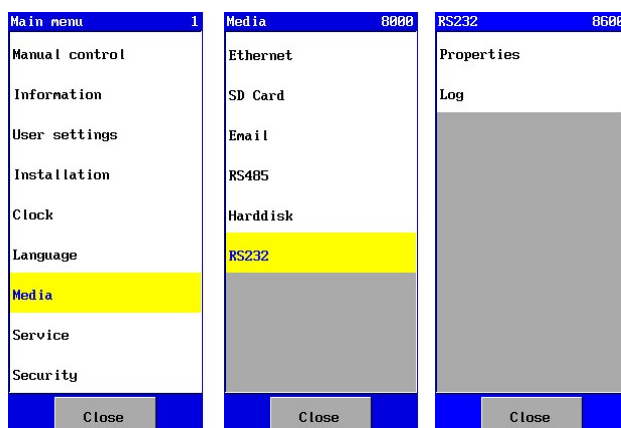

The control unit has a RS232 connection. This RS232 connection can be used for logging data (status/measurements), alarms and process data.

The settings and options for the RS232 connection are equal to the options for the RS485 connection. How everything can be set can be seen in chapter § 17 “RS485” on page 80 .

In that case the screen number needs to be increased by 200 each time.



19. Hard disk

The controller features a memory used as a hard disk.

When software files are being installed items such as languages and web pages are written to the disk. The settings are also stored here as well as the last 20 alarms .

The hard disk data may be copied to a SD card.

There are two copying functions:

- Copying function for the fitting contractor
- Copying function for the end user

19.1. Back-up via the fitting contractor

This can be done by the fitter for standard units, which nearly always have to be set the same, so the settings have to be made only once after the new software is installed. These can then be stored on a separate SD card with OEM software, see also “SD card” on page 74 (§ 15.1 t/m § 15.3), The SD card can then be used to copy the data to corresponding units.

§ 23.5 “Hard disk” on page 96 describes how “OEM back-up” can be achieved.

19.2. Back-up by the end user

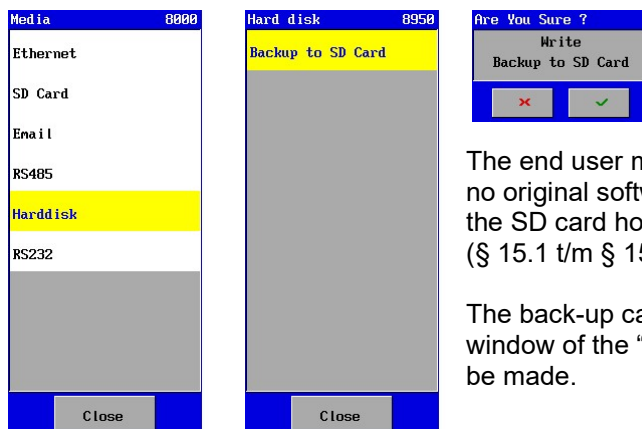

The end user may also make a back-up. A SD card on which no original software or “OEM software” is stored is placed in the SD card holder, see “SD card” on page 74 (§ 15.1 t/m § 15.3).

The back-up can be made via the “Media” menu. If the window of the “Harddisk” option is opened, the back-up can be made.

20. Logging

The controller allows various data to be logged

The data may be written to a file on the SD card or sent via e-mail, RS232 or RS485.

The following data may be singled out:

- Alarm data
- Data information (measurement and status data)
- Process data

Depending on the medium used, alarm and data information may be generated in the following formats:

- CSV format can be imported into Excel
- XML format can be directly read off in Excel (e.g. Excel 2007).

The process data is recorded in a fixed text format.

The following table shows what data can be recorded for each medium and what recording format is available.

	CSV	XML
RS485 / RS232		
Alarm	●	○
Measurem. / states	●	○
SD Card		
Alarm	●	●
Measurem. / states	●	●
E-mail		
Alarm	●	○
Measurem. / states	○	○

20.1. Alarm data

Alarms that are given can be recorded via various media (SD card, e-mail or a serial port (such as RS232 or RS485)). Alarms are routinely recorded.

Alarms are recorded including the date and time the alarm occurred. The moment when the alarm situation was removed is also recorded.

20.1.1. CSV format

If the alarms are recorded in CSV format the structure will be as follows:

<Day -Month-Year>, <Hour: Minute>, <On/off >, <Warning >, <Process>

Example:

```
09-01-2009,13:15, On, Power failure
09-01-2009,13:30, Off, Power failure
09-01-2009,15:30, On, Exceeded pressure (UF Unit: Filtration )
```

It can be seen from the above data that controller failed on 9 January 2009 at 13:15 and switched on again at 13:30. At 15:30 there was an exceeded pressure alarm during the filtration process.

Example of a file name:

AL100204.CSV : This file contains alarm log data from 04-02-2010 in CSV format.



20.1.2. XML format

If the alarms are recorded in XML format the structure will be as follows:

```
<standard XML header>(= <?xml version="1.0" encoding="UTF-8"?>)
<data>
  <object <date > <time > <status> <warning > <process> />
</data>
```

Example:

```
<?xml version="1.0" encoding="UTF-8"?>
<data>
  <object Date="09-10-2009" Time="13:30" Alarm="Off" Warning ="Power failure " />
  <object Date="09-10-2009" Time="13:30" Alarm="Off" Warning ="Exceeded pressure, UF Unit: Filtration " />
</data>
```

It can be seen from the above data that controller was activated on 9 January 2009 at 13:30. In the case of an exceeded pressure alarm, for example, the warning also shows the phase (such as Filtration) when the alarm occurred.

Example of a file name:

AL100204.XML : This file contains alarm log data from 04-02-2010 in XML format.

Attention!

If XML format is used for storage on an SD card, the file can no longer be used if the alarms logger is switched off or the SD card is deactivated. See § 15.4 "Log functions" on page 75 for more information about the switching on and off of the SD card.

20.2. Data information

The data information (measurement and status data) can be recorded via various media (SD card or serial port (bv.RS485)). The type of data and the type of format (only for SD) can be set separately for each medium. The data is recorded including the date and time.

The data is indicated as follows:

- Valves, pumps and alarm
 - 0 = turned off,
 - 1 = turned on
- Switches
 - 1 = not active,
 - 2 = active but has not passed delay time
 - 3 = still active after delay time
- Tanks (clean water tank, raw water tank and dosing tank)
 - 0 = empty
 - 50 = half full
 - 100 = full
- Measurements (flow, pressure, turbidity, temperature)
 - Measured value is indicated.



20.2.1. CSV format

If the data is recorded in CSV format the structure will be as follows:

`<Day -Month-Year>, <Hour: Minute>, <Data 1><Data n>`

When the controller is started up or the record is activated a "header" is first of all produced to indicate what the corresponding data means. You can set whether the header should be repeated after a number of data lines. See § 15.4.2 "Data log function" on page 76 (SD Card) and § 17.2.2 "Data log function" on page 81 (RS485).

The header shows what component the recorded data refers to.

The header line is established as follows:

Date, Time, xx, yy, zz,.....

xx, yy, zz, are abbreviations of the selected logging functions.

For information about the abbreviations used see § 29 "Terminology" on page 107.

The information line is established as follows:

Date, Time, aa, bb, cc,

aa, bb, cc, are the status or measurement data.

Example:

Header : dd-mm-yyyy, hh:mm, IV, FP,, UFU

data : 27-01-2010, 08:55, 1, 1,, Filtration

On 27-01-2010 at 08:55 the input valve opened, the feed pump switched on and the unit was in the "Filtration" phase.

Example of a file name:

VL100204.CSV : This file contains data log data from 04-02-2010 in CSV format.

20.2.2. XML format

If the alarms in XML format are recorded the structure will be as follows:

`<standard XML header>(= <?xml version="1.0" encoding="UTF-8"?>)`

`<data>`

`<object <date > <time > <data1> <data2> <process> />`

`</data>`

Example:

`<?xml version="1.0" encoding="UTF-8"?>`

`<data>`

`<object Date="27-01-2010" Time="08:55" IV="1" FP="1" UFU="Filtration" />`

`</data>`

On 27-01-2010 at 08:55 the input valve opened, the feed pump switched on and the unit was in the "Filtration" phase.

Example of a file name:

VL100204.XML : This file contains data log data from 04-02-2010 in XML format.

Attention!

If the XML format is used for storage on an SD card, the file can no longer be used if the data logger is switched off or the SD card is deactivated.

See § 15.4 "Log functions" on page 75 for more information about the switching on and off of the SD card.



20.3. Process data

Process data can be recorded via various media (SD card or serial port (bv.RS485)). All process changes are routinely recorded.

The data is recorded in fixed text format.

The structure is as follows:

<Day -Month-Year> <Hour: Minute> <Unit:> <Process> <Status of relay outputs>

Example:

17-02-2010 13:06 UF Unit: Standby
17-02-2010 13:06 UF Unit: Filtration : IV CV

Any power failure is also recorded with the date and time when the controller failed and with the date and time when the controller switched on again.

Example:

```
=====
Power failure: 17-02-2010 12:00 - 17-02-2010 13:20
=====
```

Example of a file name:

PL100204.TXT : This file contains process log data from 04-02-2010.



21. Modbus

Attention ! This chapter only applies to control unit type RGS8x1x-xxxx.

The controller has a Modbus compatible protocol available.

This can be realized through RS485 communication (see § 17 "RS485" at page 80) or through ethernet communication (see § 14 "Ethernet" at page 69). In this part you can read about which registers are available and how they can be read and analyzed.

21.1. Registers

21.1.1. Register : values

40001	Modbus versie				
40002-03	Flow Feed	See reg. 40075		2	M
40004-05	Flow Permeate 1	Prog.		2	M
40006-07	Flow Permeate 2	Prog.		2	M
40008-09	Flow Backwash	Prog.		2	M
40010-11	Pressure Feed 1	Prog.		2	M
40012-13	Pressure Feed 2	Prog.		2	M
40014-15	Pressure Backwash	Prog.		2	M
40016-17	Pressure Air	Prog.		2	M
40018-19	Pressure Concentrate	Prog.		2	M
40020-21	Pressure Permeate	Prog.		2	M
40022-23	Turbidity	NTU		2	M
40024	Temperature	Prog.		1	M
40025	pH 1		0,1	1	M
40026	Clean water tank	%		1	M
40027	Raw water tank	%		1	M
40028	Dosing tank 1	%		1	M
40029	Dosing tank 2	%		1	M
40030	Dosing tank 3	%		1	M
40031	Air valve			1	R
40032	Feed pump			1	R
40033	Inlet valve 1			1	R
40034	Inlet valve 2			1	R
40035	Concentrate valve 1			1	R
40036	Concentrate valve 2			1	R
40037	Permeate valve 1			1	R
40038	Permeate valve 2			1	R
40039	Backwash pump			1	R
40040	Backwash valve			1	R
40041	Permeaat dump afsluiter			1	R
40042	Dosing pump 1			1	R
40043	Dosing pump 2			1	R
40044	Dosing pump 3			1	R
40045	Alarm			1	R
40046	Alarm 2			1	R
40047	Exceeded pressure			1	I
40048	Alarm reset			1	I
40049	Stop			1	I
40050	Start backwash			1	I
40051	Start filtration			1	I
40052	Recorder 1	%		1	A
40053	Recorder 2	%		1	A
40054	Recorder 3	%		1	A



40055	Recorder 4	%		1	A
40056	Recorder 5	%		1	A
40057	Recorder 6	%		1	A
40058-59	Transmembrane pressure	Prog.		2	M
40060-74	Reserved				

M Measurement I Input
R Relay function A Analogue output (current)

Measurement :

De measurement value will be stored.

When the unity and number of decimals are predefined then this will be shown in this table. When this is programmable then this can vary and the unity and number of decimals can be read in the corresponding registers (see § 21.1.2 "Register : unities / decimals" at page. 89).

Digital inputs :

De state of the digital input function will be read bit wise :

0x8000 Function not linked to hardware in the inventory
0x4000 Function activated
0x2000 Function activated, but within delay time
0x1000 Function activated, delay time passed
0 Function not active

Relay outputs :

De state of the relay output function will be read bit wise :

When a security switch is defined then the state of this switch will also be indicated bit wise. When a analog output is defined the value (in %) will be indicated in the LSB byte.

0x8000 Function not linked to hardware in the inventory
0x4000 Relay active position
0x1000 Function activated
0x0400 Security switch activated
0x0200 Security switch activated but within delay time
0x0100 Security switch activated, delay time passed
0x00aa aa = The value of the analogue output will be shown in 1%. This is the percentage between the minimal and maximal current (0-20 or 4-20mA).

Analogue outputs :

The value of the analogue output will be shown in 1%. This is the percentage between the minimal and maximal current (0-20 or 4-20mA).

21.1.2. Register : unities / decimals

		Byte1	Byte 0	
40075	Flow Feed	Decimals	Unity	
40076	Flow Permeate 1	Decimals	Unity	
40077	Flow Permeate 2	Decimals	Unity	
40078	Flow Backwash	Decimals	Unity	
40079	Pressure Feed 1	Decimals	Unity	
40080	Pressure Feed 2	Decimals	Unity	
40081	Pressure Backwash	Decimals	Unity	
40082	Pressure Air	Decimals	Unity	
40083	Pressure Concentrate	Decimals	Unity	
40084	Pressure Permeate	Decimals	Unity	
40085	Temperature	Decimals	Unity	
40086	Transmembrane pressure	Decimals	Unity	
40087-96	Reserved			

0x8000 Value of register not valid

Unity :

0	No unity	20	°C	30	l/h	40	kPA	90	sec
1	%	21	°F	31	m3/h	41	bar	91	min
2	mA			32	gpm	42	psi	92	hour
				33	cfm			93	day

Decimals:

Number of decimals

21.1.3. Register : others

40097	Proces ID		1	
40098	Sub process nr		1	
40099	Sub process description id		1	sec.
40100	Remaining time of sub process		1	
40101-02	Service / Filtration counter		2	min.
40103-04	Remaining time until maintenance		2	min.
40105	CEB 1 : remaining number of backwashes until CEB 1		1	
40106-07	CEB 1 : remaining time until CEB 1		2	min
40108	CEB 2 : remaining number of backwashes until CEB 2		1	
40109-10	CEB 2 : remaining time until CEB 2		2	min
40111	CEB 3 : remaining number of backwashes until CEB 3		1	
40112-13	CEB 3 : remaining time until CEB 3		2	min
40150	Alarm reset			

Register 40097 : Process ID

The current process will be indicated by a number. In the table below you will find the corresponding process description.

1	Standby	7	Standby stop
2	Filtration	8	Alarm state
3	Backwash	9	Backwash 2
4	CEB 1	10	Pre flush
5	CEB 2	11	CEB 3
6	Integrity test	12	Filtration 2 (top)

Register 40098 : Sub Process ID

The number of the sub process will be indicated.

Register 40099 : Sub Process description ID

The description id of the sub process will be indicated.

For the pre flush and CEB's the following descriptions ID's are defined :

1	Air Scour	8	Air Scour 2
2	Air Scour 1	9	Drain 2
3	Drain	10	Dosing 1
4	Drain 1	11	Dosing 2
5	Backwash 1	12	Permeate dump 1
6	Backwash 2	13	Permeate dump 2
7	Soak	14	Forward Flush
255	Number of sub process will be shown		

For the integrity test the following description ID's are defined :

22	Drain		
23	Pressurizing		
24	Test		
254	Wait		

Register 40100: Remaining time of sub process

The remaining time for the current sub process will be indicated (in seconds).

Register 40150 : Alarm Reset

This register can be written with a random value. When an alarm relay was activated so this will be deactivated.



22. Internet

Attention ! This chapter only applies to control unit type UFS8x1x-xxxx.

The controller is provided with a web server and is to be used with Internet Explorer. There is a "head page", and a page with a display of the system by which the scheme is "fixed" plus a page where the controller itself is displayed. The texts on the web pages are in English.

22.1. Access via the local network (LAN)

The controller can be connected to the LAN (locale network). If the network uses a DHCP-server the controller is automatically assigned a correct IP address (when the controller starts up). Otherwise the controller will retain the IP address as specified in the Ethernet configuration data (see § 14.1.2 "IP address" on page 69).

If the PC seeks the controller web pages in the local network, both the controller's IP address and the controller's "local host name" can be entered in the browser's URL bar. The controller's "local host name" consists of the type of controller and the controller's serial number.

Example:

A type UFS8000 controller with the serial number 000002 has a local host name: "UFS8000_000002"

URL bar:

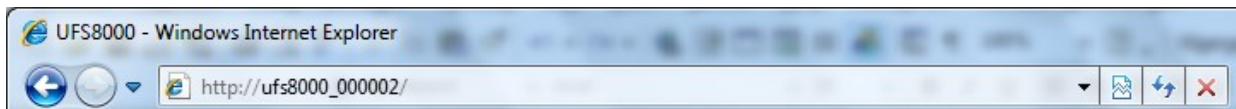

22.2. Access via internet (WAN)

It is possible to gain access to the control via the "world wide web" (internet). The IP address (WAN) of the modem to which the control is connected to, with eventually the port number, must be entered in the URL bar of the internet browser. See § 14.2 "Access via internet (WAN)" on page 70 for more information about setting up the modem and the IP number of the modem.

22.3. Security

The internet pages are secured with a user name and a password. If the controller is accessed via the HTTP connection (internet) the following window will appear. If the correct information is entered, access will be allowed to the internet pages.

The standard settings for the user name and password are:

User name	: <type of controller >	= "UFS8000"
Password	: <empty>	= ""



22.4. Head page

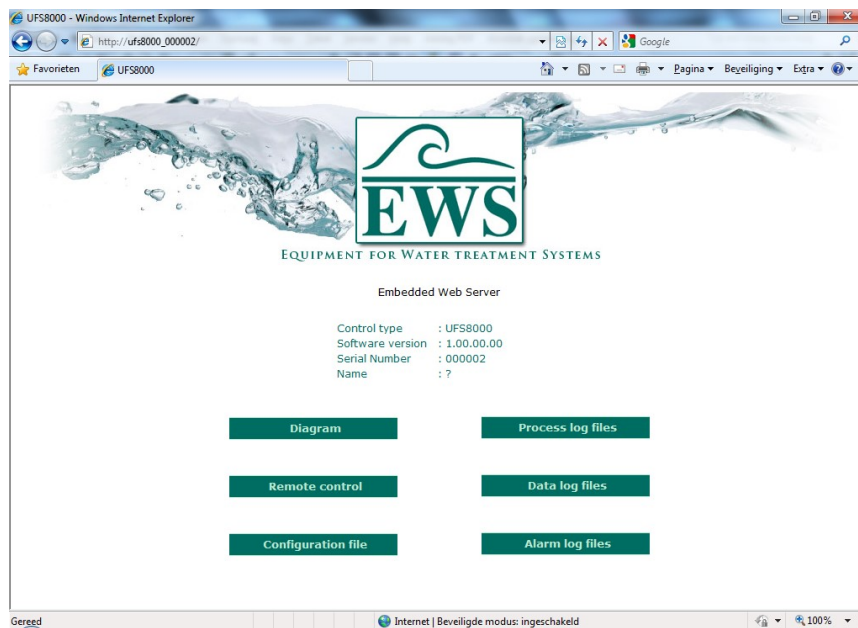

After the IP address (or “local host name”) is entered and confirmed in the URL bar and the correct user name and password are entered the above page will appear in the browser. This is the head page.

This page features information about the controller with which the connection is made.

“Control type” : The type of controller.
 “Software version” : The version of the software in the controller.
 “Serial number” : The controller's serial number
 “Name” : The controller's name
 If no name is specified in the controller, a question mark will appear here.

See § 23.3 “Names” on page 96 for entering a name.

The type of controller and the controller's name will also appear in the browser's “tab”.
 If no name is specified in the controller nothing will be displayed.

Example: without a specified name

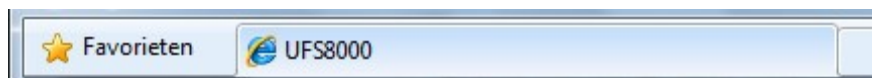

Example: with a specified name (name = oem)

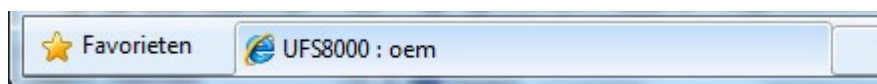

Various “links” are also made to other web pages. These web pages relate to the display of the unit, the display and operation of the controller and web pages with a list of the corresponding log files (alarm, data and process).

There is also a link (“Configuration file”) to a file where the controller's programming is stored in an easy-reference list.

Attention!

The options “Diagram” and “Remote control” are not available any more in software versions 1.05.03 and older.

22.5. Unit display

Attention!

This option is not available any more in software versions 1.05.03 and older.

The current status of the unit is schematically presented on this page. The data is refreshed every 2 seconds.

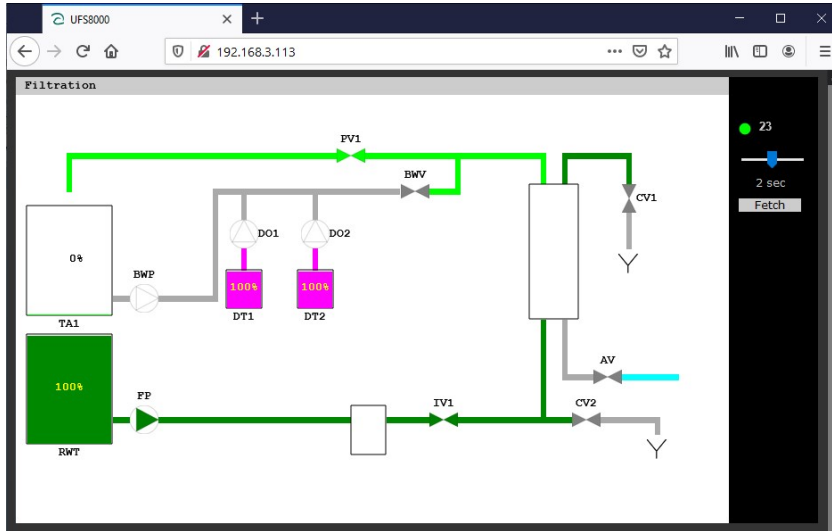

- LED communication indication
- Interval time updating front
- Immediate updating front

The above example shows only the components defined in the controller. The controller is in filtration.

22.6. Controller display / operation

Attention!

This option is not available any more in software versions 1.05.03 and older.

This page shows the current information on the LCD display. The “terminal” mode can also be used to change the settings in the controller.

After the initial start-up the LCD display is updated every 2 seconds.

When there is no updating of the front drawing it could be possible that the updating time is to short.

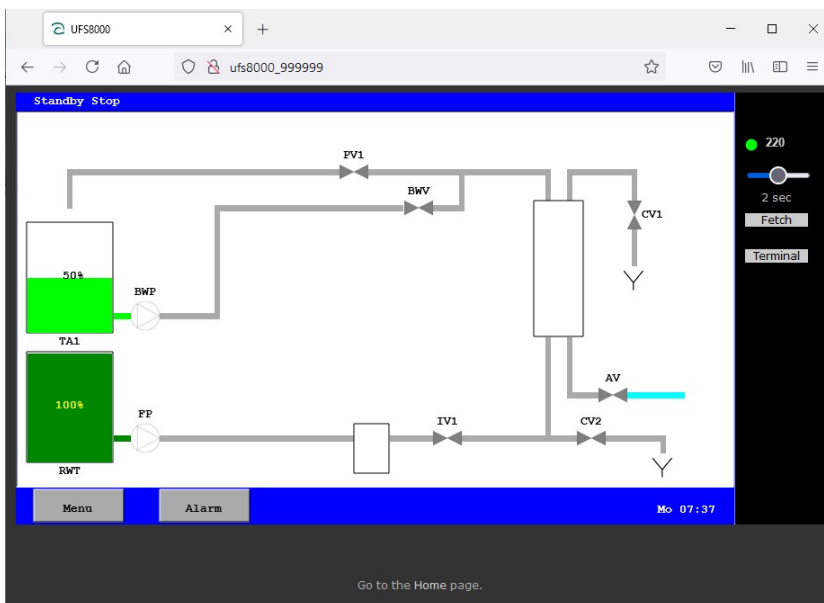

- LED communication indication
- Interval time updating front
- Immediate updating front
- Terminal mode

The touch panel allows you to deal with the control on a remote basis. The display will be renewed as soon as the touch panel is used again. If the touch panel is not used, the values will be updated according to the set interval.



22.6.1. Protection

Attention !

The security measures in this controller are normally sufficient for use in a LAN network. Wenn the controller is being used for connection through the World Wide Web then further actions for security are advised (e.g. VPN).

The internet connection can be secured in several ways. There is a possibility to have a Total Block on the communication through internet. But it is also possible to select IP addresses that will have access to the controller. Furthermore you have the possibility to select if changes to the controller are allowed through internet.

These settings are explained in § 24.2 "Internet" at page 101.

22.6.2. Terminal mode

The screenshot shows a window titled "Terminal mode" with a "Password" input field and "Send" and "Cancel" buttons.

In de terminal mode kan de besturing op afstand worden bediend. Hiertoe dient in de besturing toestemming te worden gegeven voor het maken van wijzigingen op afstand. Wordt er toestemming gegeven dan dient een wachtwoord te worden ingesteld. De terminal mode kan worden geactiveerd via de "Terminal" toets. Daarna verschijnt en

venster waarin het wachtwoord dient te worden ingegeven om toegang te krijgen tot de terminal mode. Door de toets "Send" in te drukken wordt de terminal geactiveerd. Zie ook § 24.2 "Internet" op blz. 101.

22.7. Getting log files

The internet can be used to view log files stored on the SD card.

In the main menu, pressing on the link with the required list of log files will call up a page with the available files. When no SD card is available no files will be displayed but a warning will be given that the SD card is not available.

The screenshot shows a web browser displaying a table of data log files. The table has columns for 'Nr.', 'File Name', 'File Size', and 'Creation Date'.

Nr.	File Name	File Size	Creation Date
1.	VL120328.CSV	39.290	28.03.2012 - 15:24
2.	VL120329.CSV	76.284	29.03.2012 - 07:59
3.	VL120330.CSV	10.066	30.03.2012 - 09:23

Below the table, there is a link: "Go to the home page."

Example:

The "Data log" link is pressed.

List of data log files. CSV and XML files are available on the SD card.

Data in the CSV files logged from 28-03-2012 to 30-03-2012.

Pressing on file name (link) will open the browser. If the file has to be downloaded the browser options have to be used.

Attention!

An XML file for the current day may be obtained only if the process for logging the corresponding data to the SD card is deactivated or if the SD card is deactivated, because during the deactivation period the XML file is converted to a valid file.

The SD card can be deactivated by staff onsite or via the "terminal" mode in the browser.

See § 15.4 "Log functions" on page 75 for more information about switching the SD card on and off.

22.8. "Internet key"

This software is not applicable any more.



23. Service

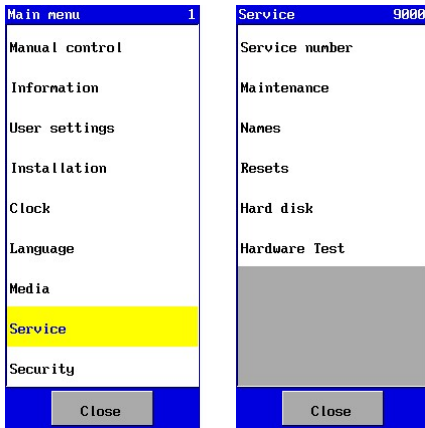

The controller's service menu allows settings to be applied for maintenance and settings, which are for authorised people only.

The service settings option is located in the main menu.

§ 4.3 “Window” on page 9 describes how a setting can be changed.

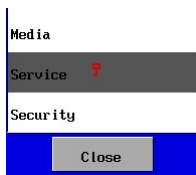

The service menu can be secured against unauthorised persons. A key then appears after “Service” to show that the option is secured (see also § 24.1.2 “Menu” on page 101).

23.1. Service number

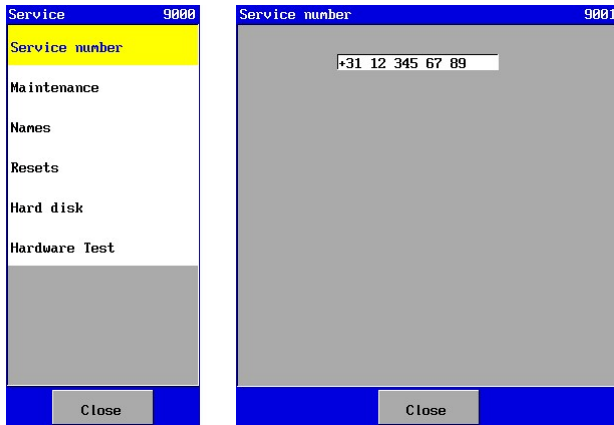

A service telephone number can be programmed in the controller. The user can ring this number in the event of any questions.

The user can view the service telephone number in the information menu (see § 10.2 “Service number” on page 60).

The service number has a maximum of 19 characters.

23.2. Maintenance

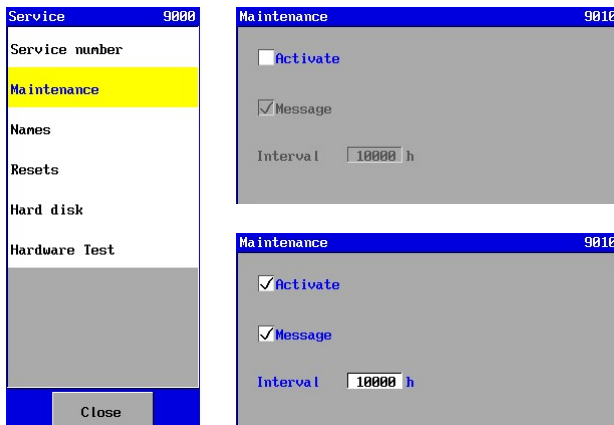

If the phase “Maintenance” is activated a “Maintenance” warning may also be activated with a related interval time. This warning can be used to warn about a maintenance activity. An interval time of between 1 and 65,000 hours may be set.



23.3. Names

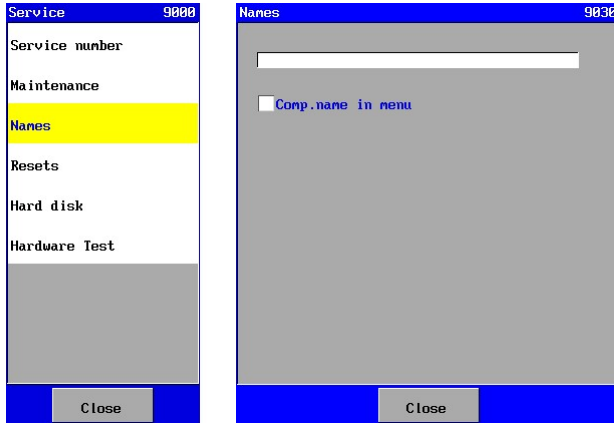

The “name” of the controller can be entered in this window. This name appears on the internet page (see § 22.4 “Head page” on page 92) to make a clear reference to a specific unit.

A name with a max. of 39 characters can be specified.

Also can be specified whether the default name will be used in the menu’s (uncheck) or the name as specified in the inventory menu (check).

See also § 5.1 “Inventory” on page 12.

23.4. Resets

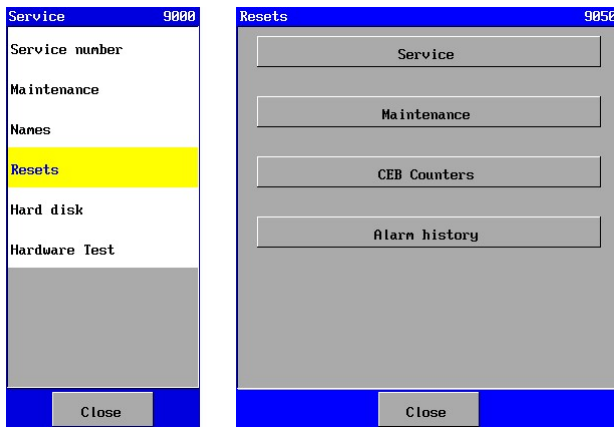

Specific records may be set in this window.

- “Service” Service hour counter set at zero.
- “Maint.” Maintenance counter set at zero.
- “CEB Counters” Interval counters for all CEBs set at zero.
- “Alarm” Alarm history deleted.

The reset is completed by pushing the reset button.

23.5. Hard disk

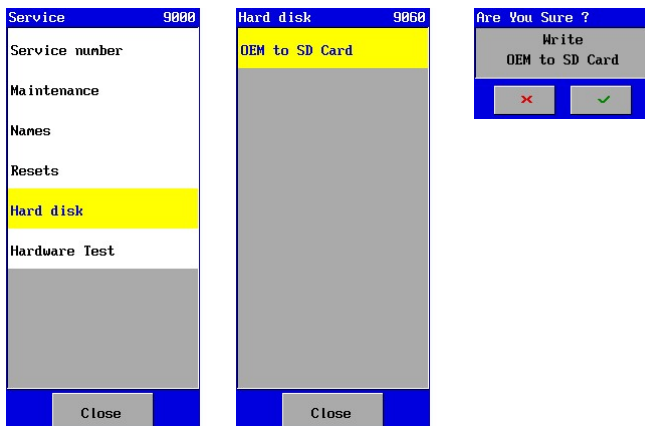

The controller’s programming is stored on an internal “hard disk”. This window can be used to copy the programming to an SD card with which, for example, a standard setting for a specific unit type can be stored.



23.6. Hardware test

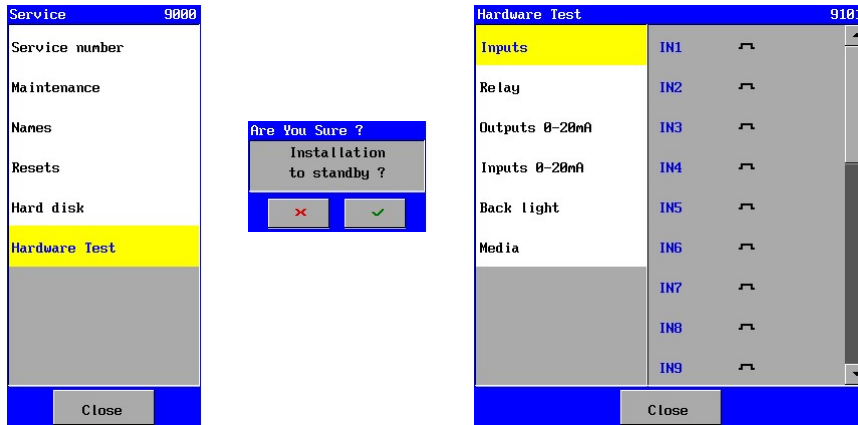

This option allows you to test the hardware in the light of the unit display and control.

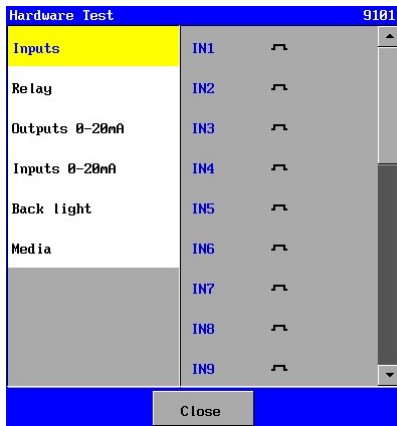

23.6.1. Inputs



The digital inputs can be tested in this window.

-  Closed input contact.
-  Opened input contact.

23.6.2. Relay outputs

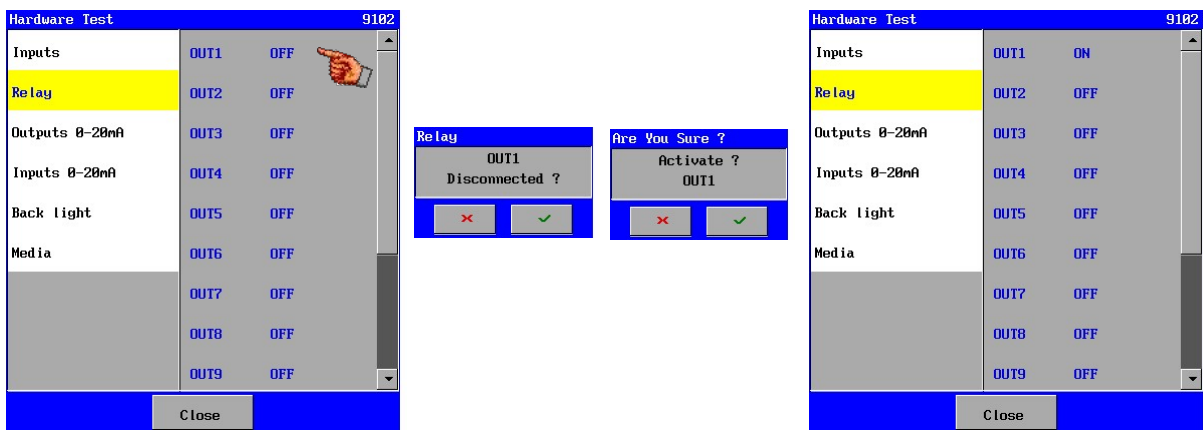

The relay outputs can be tested. A relay can be activated or deactivated by pushing the text on the touch panel, whereupon the following windows will be called up for choice confirmation and alert.

Attention!

To prevent a pump, for example, being switched on while a valve is still closed, you are advised to remove the output connections.



23.6.3. Outputs 0-20mA



The recorder output management can be controlled. In first instance, all outputs will be set at 0mA. It is possible to increase the current of a certain output by 4mA at a time. If the text is pressed at a current of 20mA, then the current will be switched off again (0mA).

This option is only displayed if the optional circuit board with recorder outputs (ca-3rec) is present.

23.6.4. Inputs 0-20mA



This window allows checking whether the 0-20mA inputs function appropriately.

A value of ca. 4000 should be displayed when power values reach 20mA. The current supply and the shown value have a linear course.

23.6.5. Back light

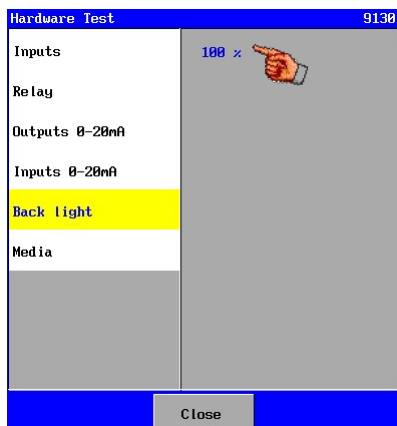

The light supply can be controlled.

It is possible to check whether the back light supply works appropriately by pushing the text box ("100%").

The supply will always switch between 50% and 100%. The lighting should be dimmed notably at 50%,.



23.6.6. Media

Attention ! This chapter only applies to control unit type UFS8x1x.

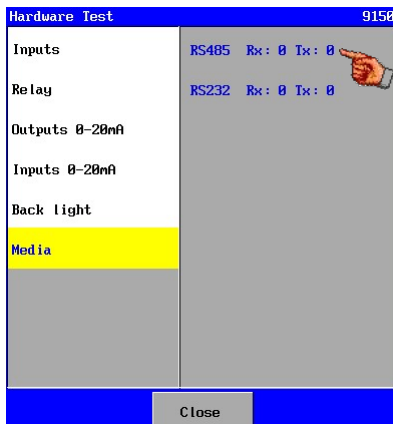

In this screen the RS232 port and the 485 port can be controlled.
The send and receive lines can be controlled independently.

The counter behind "Rx" (receive line) is increased by 1 each time a "COMTEST" message is sent by the control. This message can be sent, for example, via the PC "HyperTerminal" software (settings : baudrate=9600,databits=8,stopbits=1, parity=no).

In "HyperTerminal" the text "COMTEST" then needs to be entered, after which the "Enter" key needs to be pressed.

A message containing the type of control and the serial number will be sent by pushing the text box "Tx" of the targeted communication port. For example "UFS8000 750345" for a UFS8000 with serial number 750345. If the message has been sent, the counter behind "Tx" will be increased by 1.



24. Security

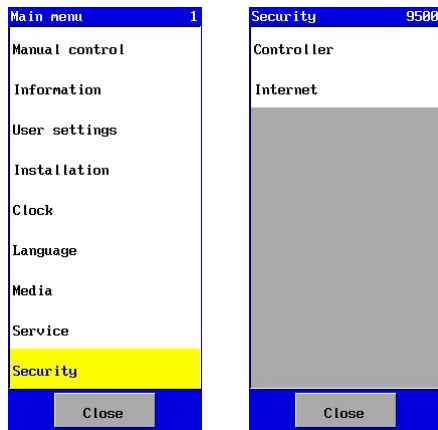

The security menu in the controller is for making settings for securing certain settings and processes and securing internet access. The settings security option is located in the main menu.

24.1. Controller

Specific settings in the menu and processes can be secured against use by unauthorised persons. A password has to be entered towards this end.

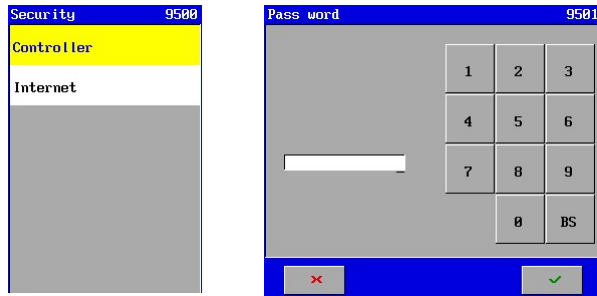

When the password is set the right password has to be entered to access this menu.

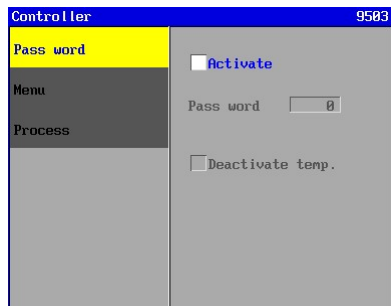

If the password is not set the menu and processes security features are not activated and nor are they shown in the menu.

24.1.1. Pass word

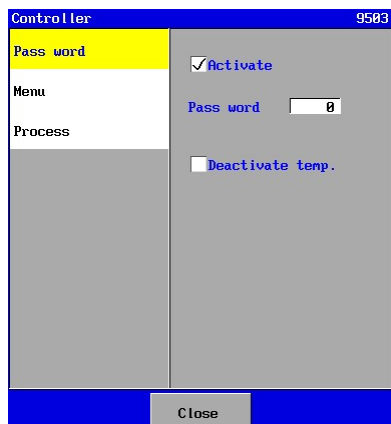

The password can be activated in this window. The password can be entered if this is activated. The password has to be a number between 0 and 9999.

The security feature may also be temporarily switched off as a result of which an authorised person can access all the settings if they remain in the menu. As soon as you quit the menu to return to the main screen the security will be automatically reactivated, thus guarding against cases where people forget to switch the security feature on again.



24.1.2. Menu

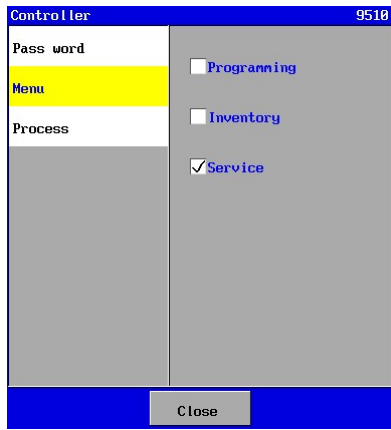

Various submenus can be secured in the menu simply by “checking the box”.

Activating a security feature for a specific component calls up a key to show the component is secured.

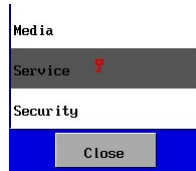

24.1.3. Process

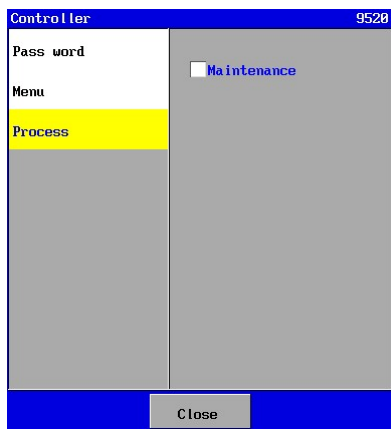

When the maintenance process is secured in the menu, no-one will be able to launch the maintenance. This security feature can be activated by “checking the box”.

The security feature first has to be turned off before the maintenance process can get underway.

24.2. Internet

Attention ! This chapter only applies to control unit type RGS8x1x-xxxx.

Attention !

The security measures in this controller are normally sufficient for use in a LAN network. When the controller is being used for connection through the World Wide Web then further actions for security are advised (e.g. VPN).

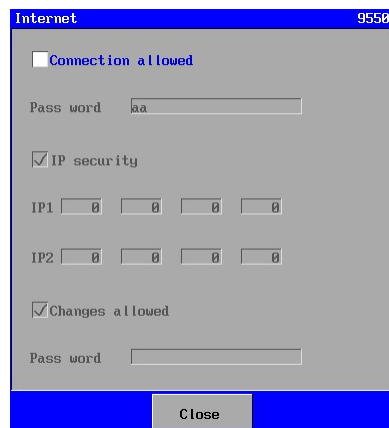
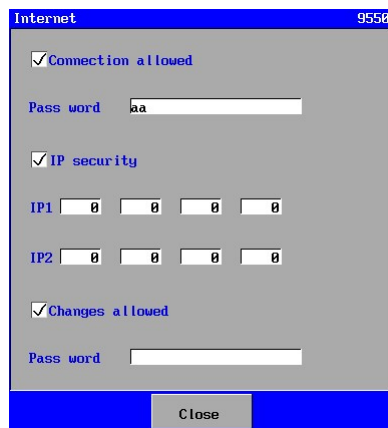
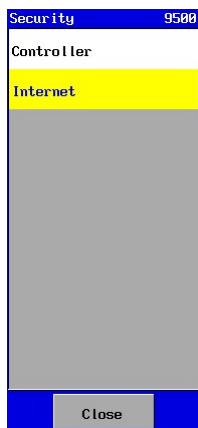

The controller has a web server which can be connected over the internet. Various securities features are set with this option.

You can set if a connection with the controller is allowed. If this is not allowed there will be communication possible with the controller through internet



You will be asked for your user name and password before a connection is made to the web server (see also § 22.3 “Security” on page 91).

The password can be changed and can be a maximum of 16 characters long.

You can set a security check on IP addresses (2 pieces). In this case only the IP addresses as set will have access to the controller.

The image shows two identical-looking web interface windows titled 'Internet' with a status '9550'. Each window contains the following elements:

- A checked checkbox for 'Connection allowed'.
- A 'Pass word' label followed by a text input field containing the characters 'aa'.
- A checked checkbox for 'IP security'.
- Two IP address input fields, labeled 'IP1' and 'IP2', each containing four empty boxes for digits.
- A checkbox for 'Changes allowed'. In the left window, this checkbox is unchecked; in the right window, it is checked.
- A 'Pass word' label followed by an empty text input field.
- A 'Close' button at the bottom center.

Settings can be changed via the internet.

When the “Changes allowed” option is switched off, the end user can disable any scope for changes via the internet.

25. Power failure

25.1. Clock

The data is stored in the event the controller's power supply fails.

The controller has a battery so the time and date can be kept. If the controller is switched on again the time and date have to be reset.

The control unit also checks whether the date is correct (year > 2009). If this is not the case, then a message will be displayed in the alarm window that the clock must be set.

In the case of summer time and winter time, the time and date have to be adjusted manually.

25.2. Alarms

Thanks to the various alarm options, a power failure is always notified when the controller is switched on again.

Exceptions to this are the alarms via an alarm relay. With the alarm relay you can choose to have the alarm relay activated or otherwise after a power failure.

See § 6.3 “Alarm” on page 22.

25.3. Programming

The controller programming is stored in a file.

The file is read off when the controller starts.

If the programming is changed the altered data will be stored when you quit the main menu but if the controller cut outs when this is in the main menu any altered data there may be will not be stored and the “old” data will be read off again after the control starts.



26. Messages

26.1. Hardware changed



If a change has been made to the hardware configuration of the control (by changing the circuit board), the above notification will appear. In this case the inventory of the components needs to be checked because it is possible that a function is no longer linked to the hardware because of removal of said hardware.



27. Boot software

27.1. General

The controller features two software programs: the boot software and the application software (for example UFS8000). If the controller is launched the boot software will first of all be opened. Explanations will be given in this chapter of the boot software and how the application software can be changed.

27.2. Changing application software

The controller will always start in the boot software whereupon the following window will appear. This shows the version of the boot software and whether a valid application is available and if so what application software is available.

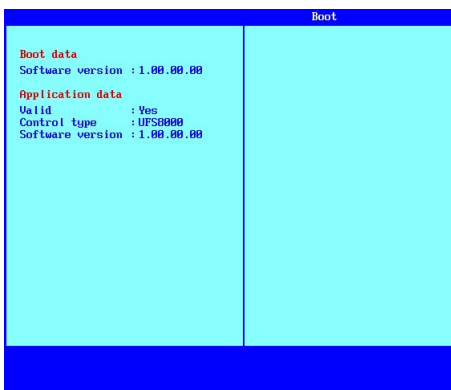

Next a check is made to see if a SD card is available in the connector intended for this purpose. If not the application software will be automatically started, provided a valid application is available.

When no valid application is available a warning appears in the display so an SD card has to be inserted with the specified software.

If the SD card is detected, an overview is provided of the software versions available on the SD card.

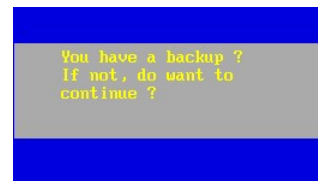
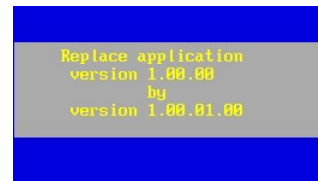
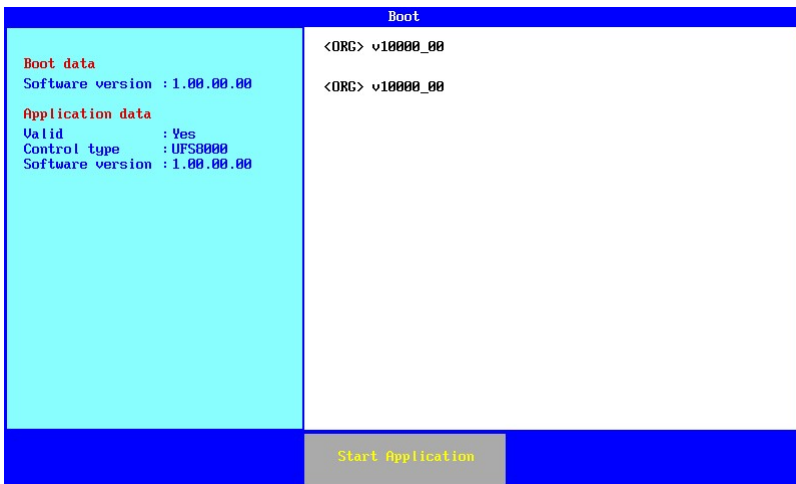

It is possible to load certain software by pushing the text of the targeted software version. If a valid application is already available in the controller, confirmation will be requested to make an update and you will then be asked whether a back-up has been made of the current software and setting.

Any valid application available will be launched.

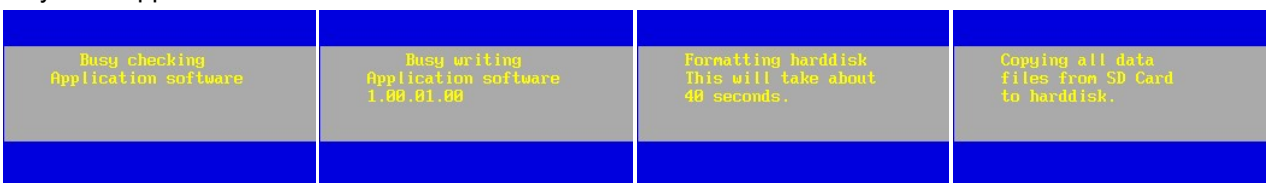

During the update a check is made first of all to see if the file on the SD card is valid. The new application is next placed in the controller whereupon the internal hard disk is formatted and any other files are placed on this hard disk.



28. Frequently asked questions

28.1. General

Question:

LCD display does not show anything.

Answer:

- Is the right power supply voltage connected?
- Is there a cable cut affecting the power supply?
- Is the power supply voltage connected to the right pins (1 + 2)?
- Are the fuses OK?
- Are the tape cables correctly connected?
- Is the contrast effectively set (P4)?

28.2. Relay outputs

Question:

Relay output does not turn on.

Answer:

- Check in the main screen to see if the output is activated.
If it is, check if the secondary fuse (F3) is OK.
If not, check the settings for the corresponding phase.

28.3. Digital inputs

Question:

Inputs not detected.

Answer:

- Is the input activated for the corresponding phase?
If it is, check if the secondary fuse (F3) is OK.
If not, change the setting for the corresponding phase.

28.4. E-mail

Question:

No e-mails sent.

Possible causes:

- Only control unit type UFS8x1x-xxxx is suitable for sending emails.
- Is the e-mail address provided correct? See § 16.1.4 "E-mail address of the recipient" on page 79.
- Is the IP address of the SMTP server correctly set? See § 16.1.2 "IP address of SMTP server" on page 78.
- Is the Default Gateway correctly set? See § 14.1.4 "Default gate-way" on page 70.
- RJ45 cable correctly connected (green LED for RJ 45 connector off?)
Does the RJ45 connector's orange LED flicker when an attempt is made to send an e-mail?



28.5. Internet

Question:

Web server page does not appear in the browser.

Possible causes:

- Only control unit type UFS8x1x-xxxx is accessible via internet.
- Is the correct IP address of the "local host name" entered? See § 14.1.2 "IP address" on page 69.
- In the event of a DHCP server: was the controller connected to network at start-up?
- RJ45 label correctly connected (green LED or RJ45 connector on?)
- Does the RJ45 connector's orange LED flicker when an attempt is made to send an e-mail?
- Is the port number correctly set? See § 14.1.5 "HTTP port number" on page 70.
- Is the Default Gateway correctly set (if contact is sought via the "World Wide Web")? See § 14.1.4 "Default gate-way" on page 70.
- Web browser possibly not compatible. Try Internet Explorer 8.

28.6. RS485

Question:

No information lines appear on the "Hyperterminal" screen.

Possible causes:

- Only control unit type UFS8x1x-xxxx is equipped with a RS485 port.
- Is the right COM port connected and set on the PC?
- Is a RS232/RS485 converter available?
- Is the connection on the controller correct (wires changed)?
- Are the baud rate, data bits, stop bits and parity appropriately set on the PC?

28.7. RS232

Question:

No information lines appear on the "Hyperterminal" screen.

Possible causes:

- Only control unit type UFS8x1x-xxxx is equipped with a RS232 port.
- Is the right COM port connected and set on the PC?
- Is the connection on the controller correct (wires changed)?
- Are the baud rate, data bits, stop bits and parity appropriately set on the PC?



29. Terminology

This chapter provides a brief explanation about the specific terms and abbreviations used in the operating manual.

Term / abbreviation	Description
SD card	“Secure Digital” card. This is a file storage medium.
XML format	“eXtensible Markup Language”. This is a general file structure for use in various types of software (such as directly opening in Excel, Access).
CSV format	“Comma Separated Value”. This is a file structure often used to record measurement data. This format can be imported into spread sheets (such as Excel)
RS232	Serial communication port which can be connected to the PC's serial COM port.
RS485	Serial communication port which (via converter) can be connected to the PC's serial COM port by means of an RS232 / RS485 converter, which is not included in the delivery.
SMTP server	Server for an e-mail message
AV	Air valve
IV	Inlet valve
FP	Feed pump
CV	Concentrate valve
PV	Permeate valve
BWP	Backwash pump
BWV	Backwash valve
DO	Dosing pump
PDV	Permeate dump valve
AL	Alarm signal
ST	Stop
HL	High-level switch
LL	Low-level switch
EP	Overpressure
RS	Alarm reset
SBW	Start Backwash
FIS	Start Filtration
FLx	Flow meter
PRx	Pressure meter
TM	Temperature meter
TUR	Turbidity
TMPR	Transmembrane pressure
RC	Recorder output (0-20 mA)

30. Overview menu

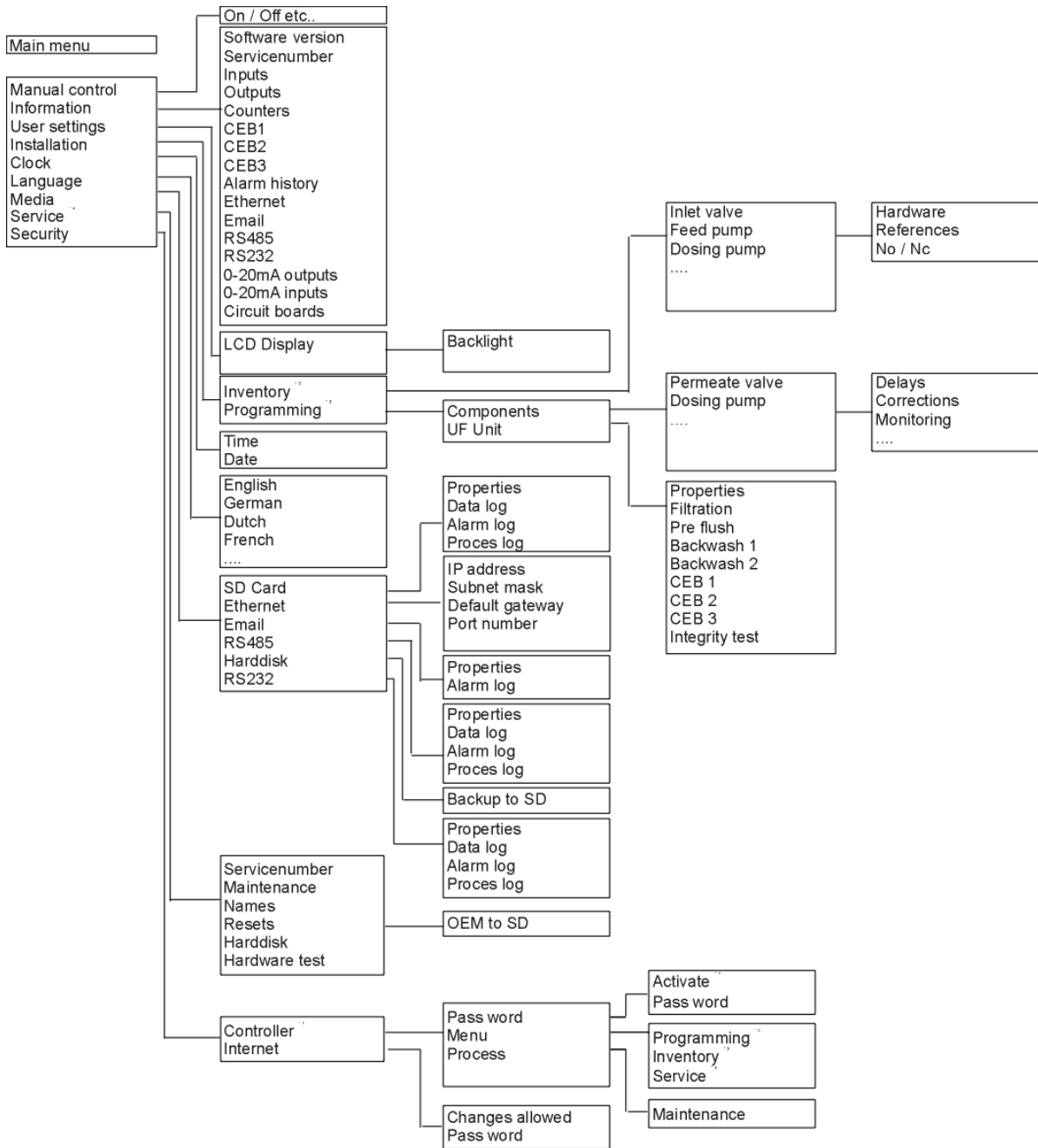



31. Opening casing

Remove the four side covers of the housing.

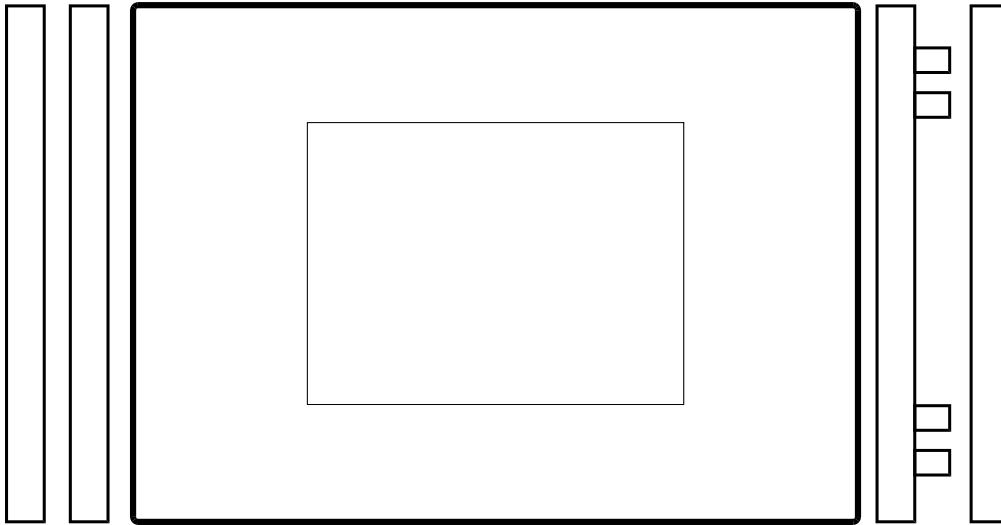

Open the housing on the left side by carefully placing the key cover between the hinge points and pushing until the front door springs open.



32. Terminal block connection

32.1. Schematics

Connection terminals UFS8xxx-XXXX

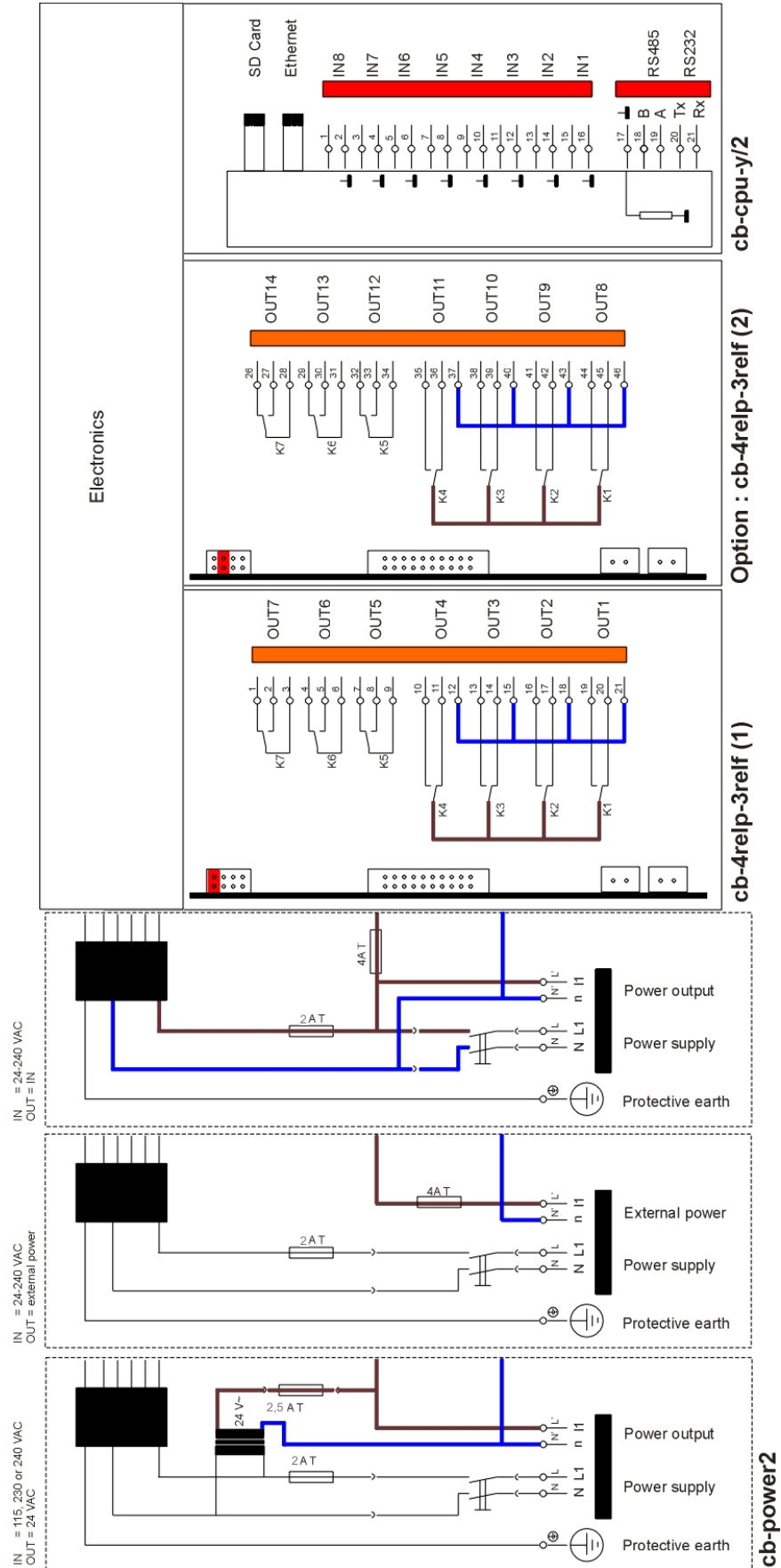

Connection terminals UFS8000 (Measure circuit boards)

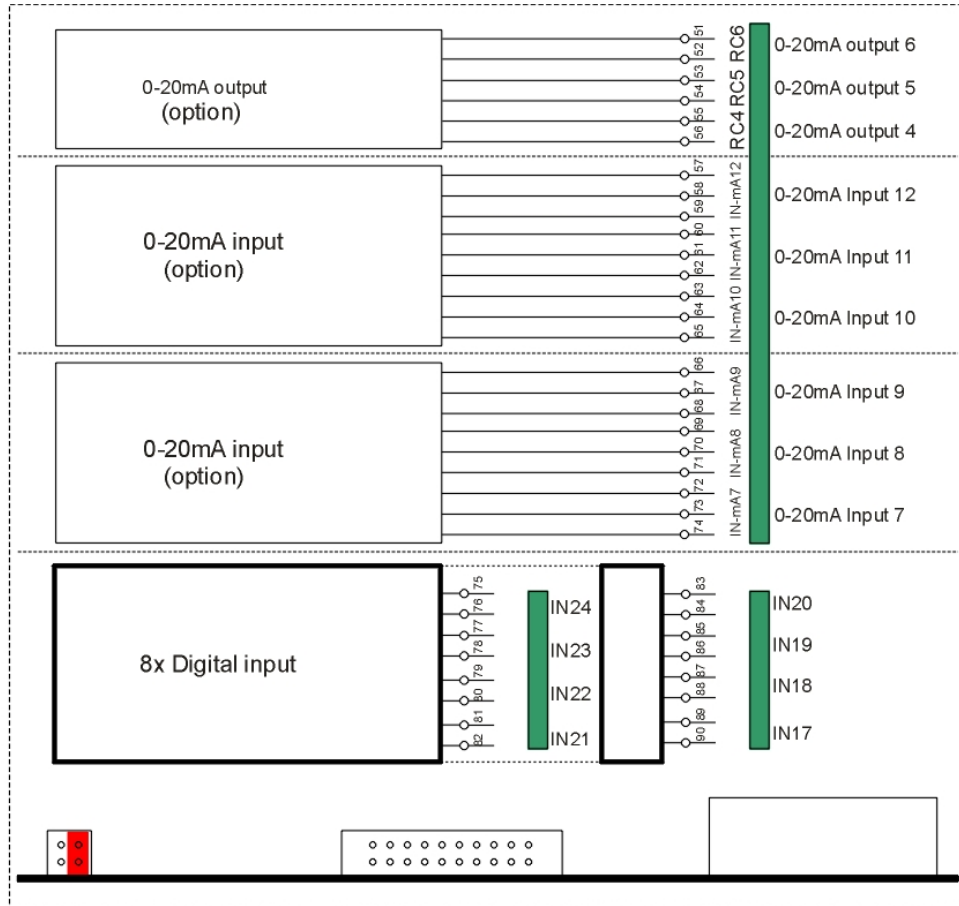

Optional : cb-8in (2)

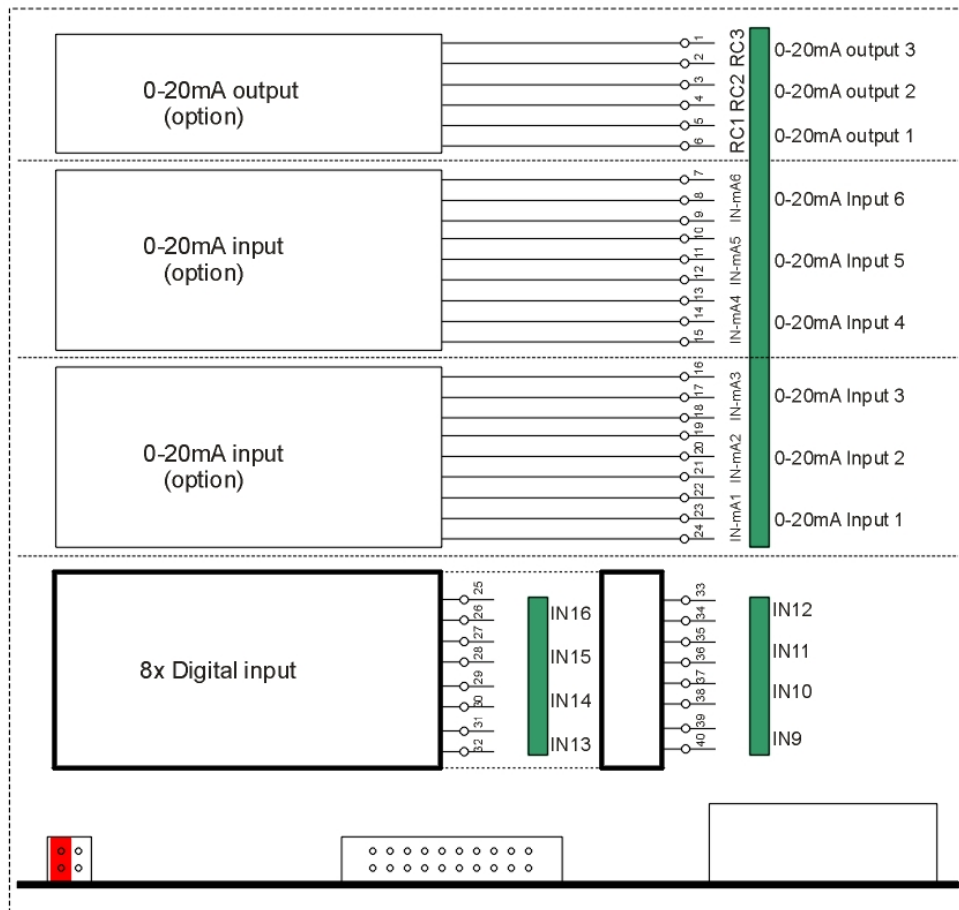

Optional : cb-8in (1)

32.2. Remarks

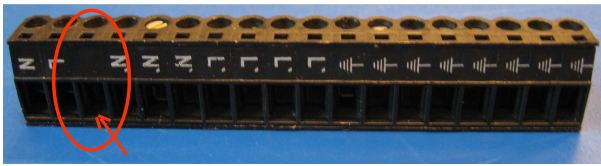

The 3th terminal of the 18 pole black connector will not be used (see picture above).

33. Electrical connection examples

Attention!

When connecting components, it is recommended to completely disconnect the power supply from the controller.

Connection of flow meter (2 wires)

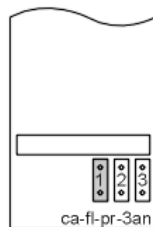
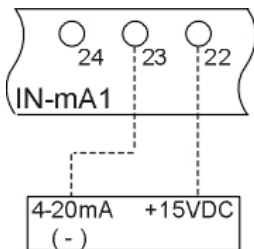

Connection of a 2-wire flow meter with a 4 – 20mA output to input IN-mA1.
A “jumper” should be placed on the “ca-fl-pr-3an” PCB as shown in the illustration.

Jumpers “2” and “3” should be installed for IN-mA2 and IN-mA3, respectively.

Connection of flow meter powered by external supply (2 wires)

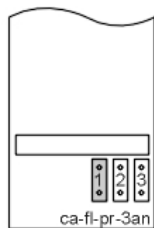
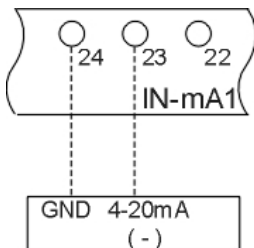

Connection of a 2-wire flow meter powered by external supply with a 4 – 20mA output to input IN-mA1.
A “jumper” should be placed on the “ca-fl-pr-3an” PCB as shown in the illustration.

Jumpers “2” and “3” should be installed for IN-mA2 and IN-mA3, respectively.

RS232 Connection

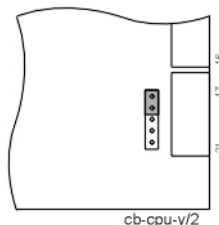
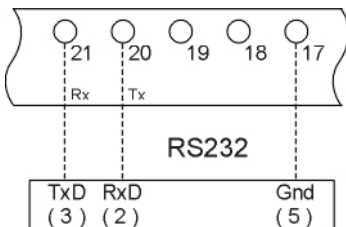

To set the communication port of the controller to “RS232”, the jumpers should be installed (cpu PCB cb-cpu-y/2) according to the illustration shown on the left.

Connector type DB9



RS485 Connection

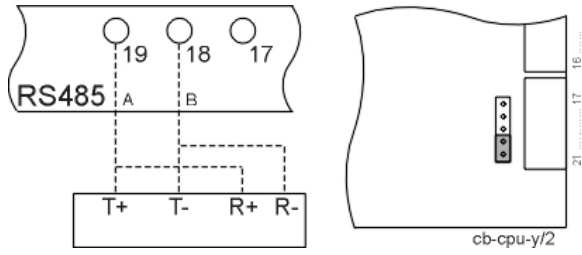

To set the communication port of the controller to "RS485" with termination resistor (120 Ohm), the jumper should be installed (cpu PCB cb-cpu-y/2) according to the illustration shown on the left.

No jumpers should be installed if no shut down threshold is wanted.



34. Installation and Start up

34.1. General

Installation and commissioning of the control system may only be carried out by trained specialists who are familiar with these operating instructions and the applicable regulations on safe working practices and accident prevention. The instructions given in this manual must always be observed and followed.

To guarantee functional operation and safety, the instructions in this manual must be followed. The manufacturer accepts no liability for damage resulting from failure to follow the instructions.

Assembly

- Do not install under damp pipes. Fit shielding if necessary.
- Insert the flush-fit unit into the 186x138 panel opening and secure using the corresponding clamps and sealing ring.
- Install device at eye level and easily accessible to the user.

Connection

- Before carrying out connection work, always ensure the control unit is first disconnected from the power supply. Make sure that the power supply remains disconnected during connection work.
- Make electrical connections. Observe local regulations.
Connect supply voltage and ground to the terminals shown in the wiring diagram.
- Make sure that the ground connection is faultless.
- If possible, keep all extra low voltage cabling (digital inputs, measurements) separate from the power supply cable.
- It is not permitted to connect the potential-free relays with a combination of 230 VAC and extra low voltage.
- The flush-fit unit is supplied without main switch. Install this main switch in the switch cabinet yourself.
- Some external relays, magnetic switches, solenoid valves, etc. can cause unwanted interference pulses when switched off.
For this reason, it is recommended that the components mentioned should be equipped with a so-called RC network in advance.
Ask the supplier of the mentioned components for the correct type of RC network.

Maintenance

The control system does not contain any user-serviceable parts. Unauthorised modifications and/or repairs to the control unit will void all warranty claims and the manufacturer's liability.

Commissioning

- Keep front lid closed at all times
- The control system may only be switched on if it is completely closed and all connections have been made correctly.

Warning

This is a class A product. In a domestic environment this product may cause radio interference in which case the user may be required to take adequate measures.



34.2. Installation

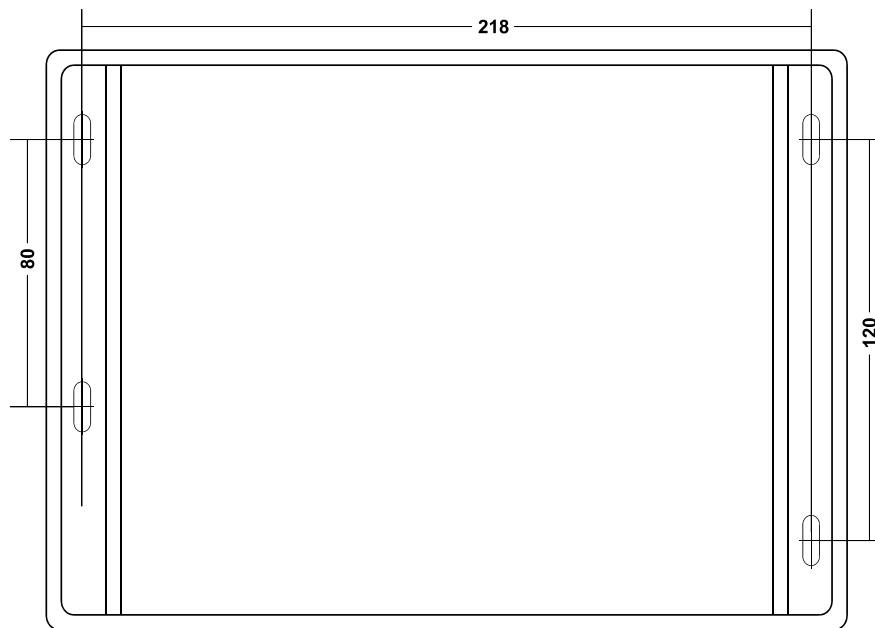

34.3. Ethernet connector

The controller can be connected to an Ethernet connection. Towards this end a RJ45 connector is placed in the controller. The RJ45 plug cannot be placed through the swivel so a ready-made cable cannot be used and one has to be assembled by the user.



35. Maintenance

The control system does not contain any user-serviceable parts. Unauthorised modifications and/or repairs to the control unit will void all warranty claims and the manufacturer's liability.

LCD display

If the "touch panel" is operated with dirty fingers, it may happen that the LCD becomes difficult to read. Should this occur the LCD display can be cleaned with a moist cloth.

Caution: Do not use chemical cleaning products for this, only water!

36. Spare parts

36.1. Order codes

Item code	Description
EH-A	Panel assembly set (4x screw, 4x insert)
EH-C-N	Side cover
EH-C-K	Key cover
EH-U-S	Transparent door

36.2. Pictures

EH-A



EH-C-N



EH-C-K



EH-U-S





37. Technical specifications

Power supply	Features: Tolerance:	24VAC, 115 VAC, 230VAC, 240 VAC, 115/24 VAC, 230/24 VAC, 240/24 VAC 10%
Power input		12 VA
Relay outputs	Powered: Potential free:	Total 4A (all powered outputs together) Total 2,5A (115/25V, 230/24V and 240/24V) 250 V, 4A per relay
Inputs		Contacts loaded 15V, 10 mA
RS232	Speed:	9600 Baud
RS485	Speed:	9600 Baud
Ethernet	Speed: Functions:	10/100 MB DHCP
Web browser		Internet Explorer 8
SD Card	Type: Format:	Standard SD, SDHC FAT12, FAT16, FAT32
CPU	Processor: Hard disk: RAM:	48 MHz 4 MB 1 MB
Protection		IP65
Ambient temperature		0 - 40 °C
Weight	IN = OUT: IN <> OUT:	ca. 2,8 kg ca. 4,0 kg
Casing	Dimensions: Built-in depth: Panel opening: Material:	240 x 174 x 107 mm 122 mm 240 x 174 mm ABS
Fuses	Relay (F2) : Primary (F1) :	4A slow or: 2,5A slow (115/25V, 230/24V and 240/24V) 2A slow
Current outputs	Max resistance:	500 Ohm
Current inputs	Supply : Supply load :	15 V max. 40 mA
CE	Immunity: Emission: Low voltage:	EN 61000-6-1, EN 61000-6-2 EN 61000-6-3, EN 61000-6-4 2006/95/EG



37.1. Casing dimensions

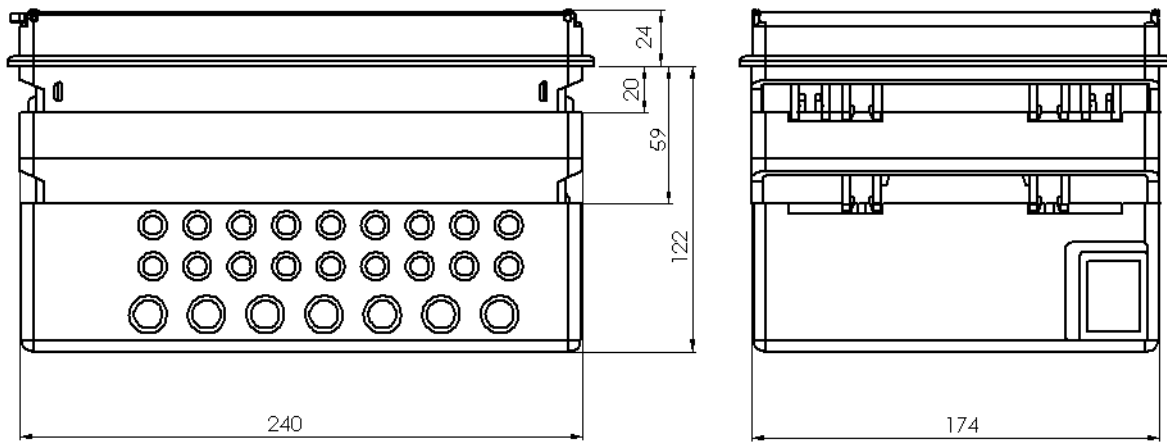

Subject to technical changes without notice



38. Index

Air valve	1, 17, 107
Alarm	1, 2, 10, 17, 22, 23, 25, 53, 54, 62, 74, 76, 79, 81, 84, 85, 96, 107
Alarm log function	76, 79
Back light	98
Backwash 1	2, 3, 16, 47, 49, 59
Backwash 2	2, 3, 16, 48, 49, 59
Backwash pump	1, 20, 107
Backwash valve	1, 18, 107
Boot software	103, 104
CEB 1	2, 3, 16, 49, 50, 58, 59, 61
CEB 2	3, 16, 49, 50, 58, 59, 62
CEB 3	16, 50, 58, 59, 62
Clean water tank	26
Clock	67, 102
Concentrate valve	1, 18, 107
Counters	61
CSV	76, 77, 79, 81, 84, 86, 94, 107
Data log function	76, 81, 86
DHCP	69, 71, 73, 91, 106, 117
Dosing pump	1, 20, 21, 107
Dosing tank	28
E-mail	1, 54, 63, 78, 79, 105
Ethernet	60, 62, 69, 73, 91, 115, 117
Exceeded pressure	23, 84, 85
Feed pump	1, 19, 107
Filtration	1, 2, 3, 18, 21, 26, 27, 28, 38, 42, 45, 46, 47, 48, 52, 57, 58, 84, 85, 86, 87, 107
Filtration 2	3, 46, 58
Flow meter	31, 32, 107
frequency regulator	1, 6, 14, 19, 20
Hard disk	83, 96, 110, 117
Hardware test	97
Informatie	66
information . 1, 3, 5, 14, 15, 16, 17, 23, 24, 25, 54, 55, 60, 61, 69, 75, 76, 77, 79, 80, 81, 82, 84, 85, 86, 91, 92, 93, 94, 95, 106	
Inlet valve	1, 12, 17, 107
inputs	1, 46, 47, 48, 49, 52, 60, 97, 105
Inputs	60, 97, 105, 117
Inputs 0-20mA	64, 98
Installation	17, 114, 115
Integrity test	2, 51, 57, 58
Internet	69, 72, 91, 94, 101, 106
Inventory	11, 12, 17
IP address	62, 69, 70, 71, 72, 73, 78, 91, 92, 105, 106
language	60, 68
LCD	1, 4, 5, 66, 93, 105
LED	93, 105, 106
Logging	84, 88
Maintenance	56, 61, 95, 96, 116
Manual	45, 52, 57
modem	70, 71, 72, 73, 91
NAPT	71, 72, 73
outputs	1, 19, 46, 47, 48, 49, 52, 60, 61, 87, 97, 105, 117
Outputs	61
Outputs 0-20mA	64, 98
Overpressure	1, 107
Pass word	100



Permeate dump valve.....	19, 107
Permeate valve.....	1, 18, 107
pH	1, 43, 44
pH meter	43
port number	70, 72, 91, 106
Power failure.....	56, 84, 85, 87, 102
Pre Flush	2, 47, 58
Pressure meter	34, 35, 107
Printed circuit board.....	65
Process log function	77, 82
Production.....	86
Protection.....	94, 117
Pumps.....	17, 19
Raw water tank.....	7, 27
Recorder	30, 107
Resets.....	96
RS232.....	1, 54, 60, 63, 65, 80, 81, 82, 84, 99, 106, 107, 112
RS485.....	1, 54, 60, 63, 64, 65, 80, 81, 82, 84, 85, 86, 87, 106, 107, 113, 117
SD card.....	1, 54, 56, 60, 74, 75, 76, 83, 84, 85, 86, 87, 94, 96, 104, 107
Security.....	91, 100
Service.....	60, 61, 95, 96
Service number	60, 95
SMTP server.....	78, 105, 107
Standby.....	2, 3, 11, 52, 53, 57, 87
Standby Stop	2, 3, 53, 57
Start backwash	25
Start Filtration	24
Stop	24, 52, 57, 80, 107
Storage tank	17, 23
Subnetmask.....	70
Switches	17, 23, 85
Tanks	26, 85
Temperature	39, 107
Temperature meter	107
Transmembrane pressure	41, 107
Turbidity meter.....	37
Valves	17, 85
XML	75, 76, 84, 85, 86, 94, 107



39. Declaration of conformity

Declaration of conformity of the product with the essential requirement of the EMC directive 2014 / 30 / EU.

Product description

Product name : Controller for ultra filtration installation
Product type : UFS8000
Manufacturer : EWS Equipment for Water treatment Systems International B.V.
Australiëlaan 12
NL-5232 BB 's-Hertogenbosch
The Netherlands

Product environment

This product is intended for use in residential en light industrial environments.

Emission standard : EN 61000-6-3
Immunity standard : EN 61000-6-2
Low voltage directive : 2006/95/EG

Report

Report number : EWS_RGS1121_3132_01

This declaration was issued by:

Date : 18-03-2020

Name : V. Naeber

Signature

: 



FIVE-YEAR CONTROLLER LIMITED WARRANTY

LIMITED WARRANTY

EWS International (hereafter EWS) warrants her products free from defects in material and workmanship under the following terms.

In this warranty, "Products" shall be taken to mean all devices that are supplied pursuant to the contract with exception of software.

VALIDITY OF THE WARRANTY

Labour and parts are warranted for five years from the date of the first customer purchase. This warranty is only valid for the first purchase customer.

Notwithstanding the warranty period of five years as mentioned above - while upholding the remaining provisions – a warranty period of three months applies to the supply of software.

COVER OF THE WARRANTY

Subject to the exceptions as laid down below, this warranty covers all defects in material or workmanship in the EWS products. The following are not covered by the warranty:

- 1) Any product or part not manufactured nor distributed by EWS. EWS will pass on warranty given by the actual manufacturer of products or parts that EWS uses in the product.
- 2) Any product, on which the serial number has been defaced, modified or removed.
- 3) Damage, deterioration or malfunction resulting from:
 - a) Accident, misuse, neglect, fire, water, lightning or other acts of nature.
 - b) Product modification or failure to follow instructions supplied by the products.
 - c) Repair or attempted repair by anyone not authorized by EWS.
 - d) Any shipment of the product (claims must be presented to the carrier)
 - e) Removal or installation of the product
 - f) Any other cause, which does not relate to a product defect.
 - g) Cartons, equipment enclosures, cables or accessories uses in conjunction with the product.

FINANCIAL CONSEQUENCES

EWS will only pay for labour and material expenses for covered items, proceed from repairs and updates done by EWS at the EWS location. EWS will not pay for the following:

- 1) Removal or installations charges at customers and/or end user location.
- 2) Costs for initial technical adjustments (set-up), including adjustment of user controls or programming.
- 3) Shipping charges proceed from returning goods by the customer. (Shipping charges for returning goods to the customer are for the account of EWS).

All the costs which exceed the obligations of EWS under this Warranty, such as, but not limited to, travel and accommodation costs and costs for assembly and dismantling are for the account and risk of the customer.

WARRANTY SERVICE

In order to retain the right to have a defect remedied under this warranty, the customer is obliged to:

- 1) Submit complaints about immediately obvious errors related to the products delivered, in writing within eight days of the delivery of the products and submit complaints about shortcomings relating to the products delivered, which are not visible, within eight days of their being discovered.
- 2) Return defected products for account and risk of the customer. Costs for this shipment will not be reimbursed by EWS. The products may only be returned following express, written permission from EWS. Returning the products does not affect the obligation to pay the invoiced amounts.



- 3) Present the original dated invoice (or a copy) as proof of warranty coverage, which must be included in any [of the] return shipment of the product. Please include also in any mailing a contact name, company, address and a description of the problem(s).

LIMITATION OF IMPLIED WARRANTIES

Except where such disclaimers and exclusions are specifically prohibited by applicable law, the foregoing sets forth the only warranty applicable to the product, and such warranty is given expressly and in lieu of all other warranties, express or implied, or merchantability and fitness for a particular purpose and all such implied warranties which exceed or differ from the warranty set forth herein are hereby disclaimed by EWS.

EXCLUSION OF DAMAGES

EWS' liability for any defective products is limited to the repair or replacement of the product at our option. Except where such limitations and exclusions are specifically prohibited by applicable law EWS shall not be liable for:

- 1) Damage to other property caused by defects in the EWS product, damages based upon inconvenience, loss of use of the product, loss of time, commercial loss or:
- 2) Any damages, whether incidental, [consequential or otherwise] special, indirect or consequential damages, injury to persons or property, or any other loss.

Under no circumstances whatsoever shall EWS be obliged to provide compensation beyond the direct damage incurred by customer up to an amount not exceeding the payment receivable from the insurer of EWS in connection with the damage.

APPLICABLE LAW AND DISPUTES

- 1) Dutch law shall govern all offers made by EWS and all agreements concluded between EWS and customer. This warranty explicitly excludes application of the Vienna Sales Convention (CISG).
- 2) All disputes which may arise between the parties shall be dealt with exclusively by the competent court of law in the Netherlands under whose jurisdiction EWS falls. However, EWS reserves the right to submit any disputes to the competent court in the customer's location.